

Features

- 0-90 second field replaceable time delay retard
- Easy to read retard time delay adjustment knob
- Two SPDT (form C) contacts
- Weatherproof
- Easy to read wire terminal designations
- 5 year warranty

WARNING

- Installation must be performed by qualified personnel and in accordance with all national and local codes and ordinances.
- Shock hazard. Disconnect power source before servicing. Serious injury or death could result.
- Risk of explosion. Not for use in hazardous locations. Serious injury or death could result.



Description

The Model VSR-C is a vane type waterflow switch for use on wet sprinkler systems. It is UL Listed for use on Type K, L, and M copper pipe, sizes 2" thru 4" (50mm - 100mm).

The VSR-C may also be used as a sectional waterflow detector on large systems.

The VSR-C contains two single pole, double throw, snap action switches and an adjustable, instantly recycling pneumatic retard. The switches are actuated when a flow of 10 GPM (38 LPM) or more occurs downstream of the device. The flow condition must exist for a period of time necessary to overcome the selected retard period.

Enclosure

The VSR-C switches and retard device are enclosed in a weather/UV/flame resistant high impact composite plastic. The cover is held in place with two tamper resistant screws which require a special key for removal. A field installable cover tamper switch is available as an option which may be used to indicate unauthorized removal of the cover. See bulletin number 5401103 for installation instructions of this switch.

Technical Specifications

Conduit Entrances	Two knockouts provided for 1/2" conduit Individual switch compartments suitable for dissimilar voltages	
Contact Ratings	Two sets of SPDT (Form C) 10.0 Amps at 125/250VAC 2.0 Amps at 30VDC Resistive 10 mAmps min. at 24VDC	
Enclosure	Cover - Weather/UV/Flame Resistant High Impact Composite Base - Die-cast aluminum	
Environmental Specifications	NEMA 4/IP54 Rated Enclosure suitable for indoor or outdoor use with factory installed gasket when used with appropriate conduit fitting. Temperature range: 40°F / 120°F, 4,5°C/49°C Non-corrosive sleeve factory installed in saddle.	
Maximum Surge	18 FPS (5,5 m/s)	
Minimum Flow for Alarm	4-10 GPM (15-38 LPM) - UL	
Service Pressure	175 PSI (12,1 BAR) - UL	
Service Use	Automatic Sprinkler One or two family dwelling Residential occupancy up to four stories National Fire Alarm Code	NFPA-13 NFPA-13D NFPA-13R NFPA-72

Installation (See Fig. 1)

These devices may be mounted on horizontal or vertical pipe. On horizontal pipe they should be installed on the top side of the pipe where they will be accessible. The device should not be installed within 6" (15 cm) of a fitting which changes the direction of the waterflow or within 24" (60 cm) of a valve or drain.

Note: Do not leave cover off for an extended period of time.

Drain the system and drill a hole in the pipe using a hole saw in a slow speed drill. (see Fig. 1)

Clean the inside pipe of all growth or other material for a distance equal to the pipe diameter on either side of the hole.

Roll the vane so that it may be inserted into the hole; do not bend or crease it. Insert the vane so that the arrow on the saddle points in the direction of the waterflow. Install the saddle strap and tighten nuts alternately to required torque. (see Fig. 1). The vane must not rub the inside of the pipe or bind in any way.

Specifications subject to change without notice.

Fig. 1

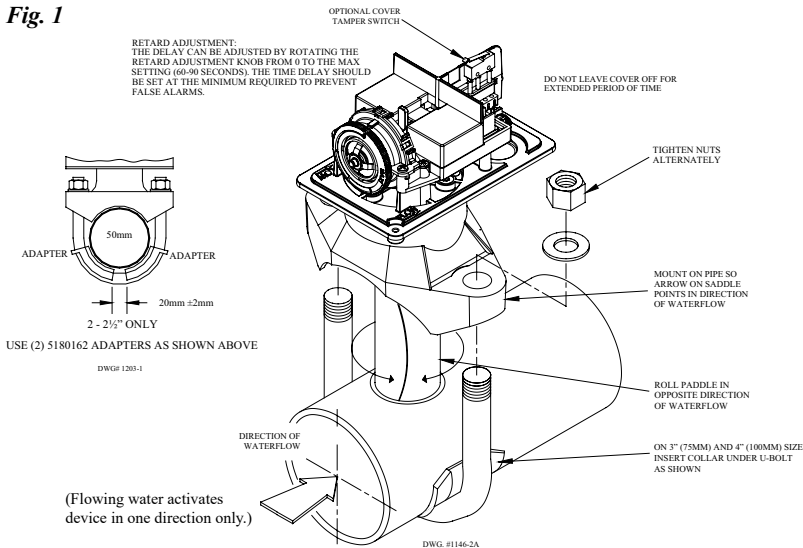

Switch Terminal Connections
Clamping Plate Terminal

Fig. 2

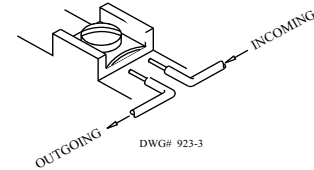

WARNING

An uninsulated section of a single conductor should not be looped around the terminal and serve as two separate connections. The wire must be severed, thereby providing supervision of the connection in the event that the wire become dislodged from under the terminal. Failure to sever the wire may render the device inoperable risking severe property damage and loss of life.

CAUTION

Waterflow switches that are monitoring wet pipe sprinkler systems shall not be used as the sole initiating device to discharge AFFF, deluge, or chemical suppression systems. Waterflow switches used for this application may result in unintended discharges caused by surges, trapped air, or short retard times.

Installation Requirements							
Model	Nominal Pipe Size	Nominal Pipe O.D.		Hole Size		U-Bolt Nuts Torque	
		inch	mm	inch	mm	in-lb	n-m
VSR-C 2"	2	2.375	60.3	1.25 ± .062	33.0 ± 2.0	100	11,3
VSR-C 2½"	2½	2.875	73.0				
VSR-C 3"	3	3.500	88.9	2.00 + .062/- .125	50.8 ± 2.0		
VSR-C 4"	4	4.500	114.3				

Typical Electrical Connections

Fig. 3

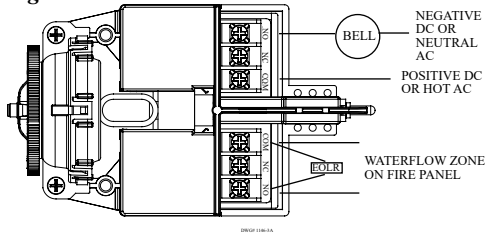

Notes:

1. The Model VSR-C has two switches, one can be used to operate a central station, proprietary or remote signaling unit, while the other contact is used to operate a local audible or visual annunciator.
2. For supervised circuits see "Switch Terminal Connections" drawing and caution note (Fig. 2).

Testing

The frequency of inspection and testing for the Model VSR-C and its associated protective monitoring system should be in accordance with applicable NFPA Codes and Standards and/or the authority having jurisdiction (manufacturer recommends quarterly or more frequently).

If provided, the inspector's test valve, that is usually located at the end of the most remote branch line, should always be used for test purposes. If there are no provisions for testing the operation of the flow detection device on the system, application of the VSR-C is not recommended or advisable.

A minimum flow of 10 GPM (38 LPM) is required to activate this device.

Maintenance

Inspect detectors monthly for leaks. If leaks are found, replace the detector. The VSR-C waterflow switch should provide years of trouble-free service. The retard and switch assembly are easily field replaceable. In the unlikely event that either component does not perform properly, please order replacement retard switch assembly stock number 1029030. There is no maintenance required, only periodic testing and inspection.

Break out thin section of cover when wiring both switches from one conduit entrance.

Fig. 4

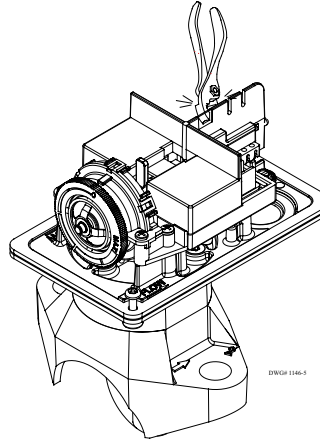

To remove knockouts: Place screwdriver at inside edge of knockouts, not in the center.

Fig. 5

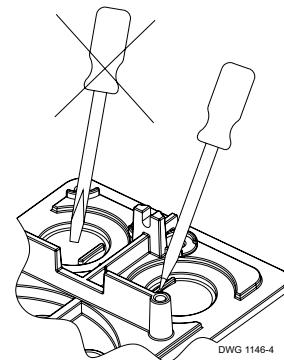

Removal

- To prevent accidental water damage, all control valves should be shut tight and the system completely drained before waterflow detectors are removed or replaced
- Turn off electrical power to the detector, then disconnect wiring
- Loosen nuts and remove U-bolts
- Gently lift the saddle far enough to get your fingers under it. With your fingers, roll the vane so it will fit through the hole while continuing to lift the waterflow detector saddle
- Lift detector clear of pipe

Important Notice

Please advise the person responsible for testing of the fire protection system that this system must be tested in accordance with the testing instructions.

Mounting Dimensions

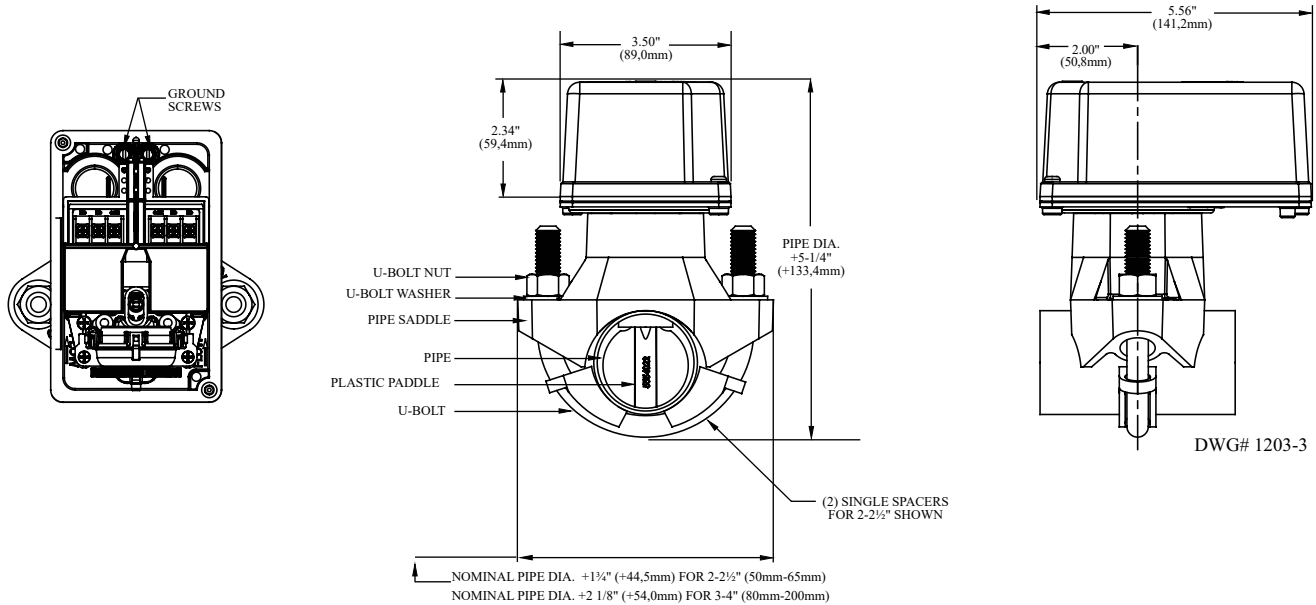

Ordering Information			
Model	Nominal Pipe Size		Stock Number
VSR-C 2"	2"	50mm	1144450
VSR-C 2 1/2"	2 1/2"	65mm	1144451
VSR-C 3"	3"	80mm	1144452
VSR-C 4"	4"	100mm	1144453

Optional: Cover Tamper Switch Kit, Stock No. 0090148

Replaceable Components: Retard/Switch Assembly, stock no. 1029030