



Stock No. 1111100

U.S. Patent No. 3921989, Canadian Patent No. 1009680

Other Patents Pending

⚠ WARNING

Install VS-SP in systems that are not subject to variable water pressure. Failure to do so will result in false alarms.

⚠ CAUTION

This device is not intended for applications in explosive environments.

UL, cUL, CSFM and NYBSA Listed, CE Marked

Service Pressure: Up to 250 PSI (17,2 BAR)

Minimum Flow Rate for Alarm: 10 GPM (38 LPM)

Maximum Surge: 18 FPS (5,5 m/s)

Enclosure: Die-cast, red enamel finish
Cover held in place with tamper resistant screws

Contacts: One set of SPDT (Form C), standard
Second set optional, see below:
15 Amps at 125/250VAC
0.5 Amps at 125VDC
0.25 Amps at 250VDC
2.5 Amps at 30 VDC resistive

Conduit Entrance: One opening for 1/2" conduit

Usage: Listed plastic, copper and schedule 40 iron pipe
For pipe sizes - 1" (25mm), 1-1/4" (32mm), 1-1/2" (38mm),
and 2" (50mm)

Note: 12 paddles are furnished with each unit, one for each pipe size of threaded and sweat TEE, one for 1" CPVC, one for 1" CPVC (Central), one for 1" Nibco threaded tee, and one for 1-1/2" threaded (Japan).

Environmental Specifications:

- Suitable for indoor or outdoor use with factory installed gasket and die-cast housing.
- NEMA 4/IP55 rated enclosure - use with appropriate conduit fitting.
- Temperature range: 40°F to 120°F (4,5°C to 49°C)

Service Use:

Automatic Sprinkler	NFPA-13
One or two family dwelling	NFPA-13D
Residential occupancy up to four stories	NFPA-13R
National Fire Alarm Code	NFPA-72

Optional: Extra Contacts Switch Kit, Stock No. 0090013
(Extra Contacts Switch is Field Installed)
Cover Tamper Switch Kit, Stock No. 5420220

The Model VS-SP is a vane type waterflow switch for use on wet sprinkler systems. These devices may be used as sectional flow indicators on large sprinkler systems and on smaller sprinkler systems such as mobile homes and residential dwellings.

The VS-SP does not have a retard to prevent false alarms due to water surges. Therefore it should NOT be used on systems with variable water pressure supplies except in the case of elevator recall.

Installation

These devices may be mounted in horizontal or vertical pipe. On horizontal pipe they should be installed on the top side of the pipe where they will be accessible. The units should not be installed within 6" (15cm) of a valve, drain or fitting which changes the direction of the water flow. Select the proper paddle for the pipe size and type of TEE used. See Fig. 1 for instructions on how to change the paddle.

The unit has a 1" NPT bushing for threading into a non-corrosive TEE.

See Fig. 2 for proper TEE size, type and installation. Use no more than three wraps of teflon tape as thread lubricant. Screw the device into the TEE fitting as shown in Fig. 2. Care must be taken to properly orient the device for the direction of waterflow.

The vane must not rub the inside of the TEE or bind in any way. The stem should move freely when operated by hand.

Testing

Check the operation of the unit by opening the inspector's test valve at the end of the sprinkler line, or the drain and test connection if a test valve is not provided.

If there are no provisions for testing the operation of the flow detection device on the system, application of the VS-SP is not recommended or advisable.

Fig. 1

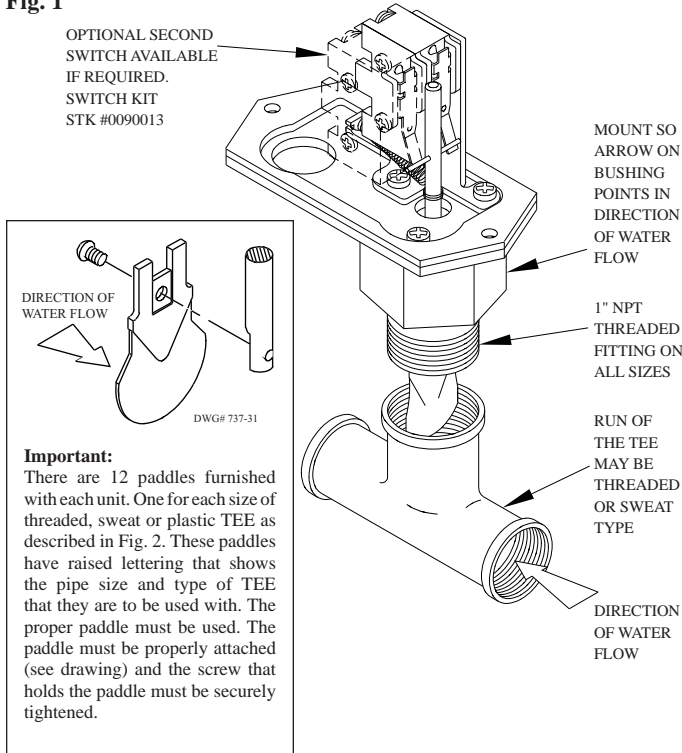
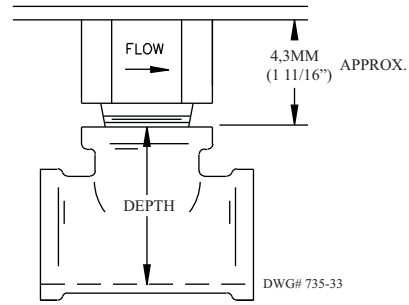

Fig. 2



Screw the device into the tee fitting as shown. Care must be taken to properly orient the device for the direction of waterflow. On sweat tees, no threaded bushings, inserts, or adapters are permitted, unless they comply with the dimensions listed in the chart below.

Important - The depth to the inside bottom of the tee should have the following dimensions:

⚠ WARNING

Do not use more than three wraps of teflon tape.

Switch Information

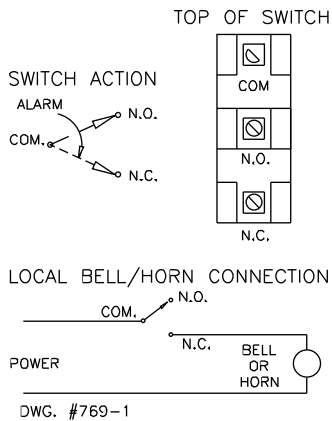

Typical Control Panel Connections

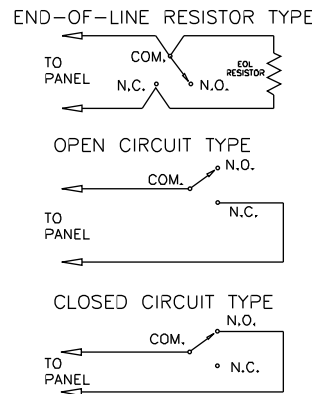

Switch Terminal Connections Clamping Plate Terminal

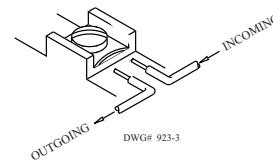

⚠ CAUTION

An uninsulated section of a single conductor should not be looped around the terminal and serve as two separate connections. The wire must be severed, thereby providing supervision of the connection in the event that the wire becomes dislodged from under the terminal.

⚠ WARNING

Due to the possibility of unintended discharges caused by pressure surges, trapped air, or short retard times, waterflow switches that are monitoring wet pipe sprinkler systems shall not be used as the sole initiating device to discharge AFFF, deluge, or chemical suppression systems.

Note: The Model VS-SP has one SPDT switch. An optional second switch is available if required. For example, one switch would connect to an annunciator panel, and the optional switch could be used to operate a local bell. Order Switch Kit No. 0090013.

Testing

The frequency of inspection and testing for the Model VS-SP and its associated protective monitoring system should be in accordance with applicable NFPA Codes and Standards and/or the authority having jurisdiction (manufacturer recommends quarterly or more frequently).