

## Technical Data

# BiRotor Plus Positive Displacement Meter

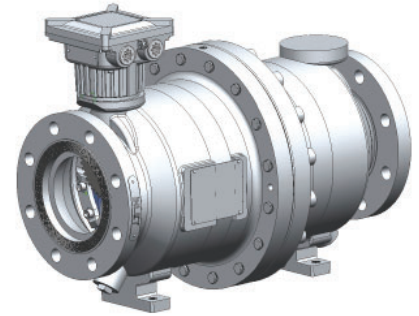

B27X	3" ANSI (DN80)	B30X	6" ANSI (DN150)
B28X	4" ANSI (DN100)	B31X	8" ANSI (DN200)
B29X	6" ANSI (DN150)	B32X	10" ANSI (DN250)

### General

The BiRotor Plus is an extremely accurate dual cased flow measuring device. It produces via the use of non wetted pickoffs a high resolution signal which is directly proportional to the rate of liquid flow through the meter. These signals are shaped by a simple internal pre-amplifier for transmission to ancillary equipment.

The BiRotor Plus Meter utilizes the exclusive BiRotor principle. There are no sliding, oscillating, or reciprocating parts.

### Accuracy

The BiRotor Plus meter is the most accurate PD meter in the market. Outperforming any other meter in the industry, this meter is capable of a linearity of +/- 0.075% with a repeatability of 0.02%.

### Linearity

B27X Standard Rotors  
 +/- 0.1% Over Standard Flow Range  
 +/- 0.15% Over Extended Flow Range

B28X and B29X Standard Rotors  
 +/- 0.075% Over Standard Flow Range  
 +/- 0.15% Over Extended Flow Range

B3XX Standard Rotors  
 +/- 0.15% Over Standard Flow Range

B285 and B305 BiRotor Plus  
 +/- 0.1% Linearity  
 0.020% Repeatability

### Dependability

There is no metal to metal contact between the rotors and the measurement chamber. The meter is therefore extremely durable. The rotors, bearings and timing gears are the only moving parts. Maintenance requirements are the lowest in the industry.

### Affordability

No premium for superior performance. Brodie offers the BiRotor Plus at a very competitive price.

### Flexibility

The BiRotor plus meter can be installed either vertically or horizontally. It offers direct pulse output. And it is field proven in thousands of installations.

### Repeatability

(All Sizes):  
 0.02% std. Rotors  
 0.04% X-Clearance  
 [Premium accuracy is also available]

### Viscosity Range

Standard: 0.2 - 1000 cSt

### Operating Temperature

STD: -20°F to 167°F (-29°C to 75°C)  
 Low: -40°F to 167°F (-40°C to 75°C)  
 High: 14°F to 230°F (-10°C to 110°C)

## Flow Ranges

MODEL		GPM		BPH		l/min		m3/h		Nominal K-Factor +/-10%
		min	max	min	max	min	max	min	max	
B27X	standard	43	425	61	607	163	1609	10	97	160 PUL/GAL 42 PUL/L
	extended	30	500	43	714	114	1893	7	114	
B28X	standard	70	700	100	1000	265	2650	16	159	96 PUL/GAL 25 PUL/L
	extended	33	1000	47	1429	125	3785	7	227	
B285	standard	97	971	131	1310	256	2562	21	208	96 PUL/GAL 25 PUL/L
B29X	standard	100	1000	143	1429	379	3785	23	227	96 PUL/GAL 25 PUL/L
B30X	standard	175	1750	250	2500	662	6624	39	397	40 PUL/GAL 11 PUL/L
B305	standard	175	1750	250	2500	662	6624	39	397	40 PUL/GAL 11 PUL/L
B31X	standard	281	2818	402	4025	1066	10667	64	640	40 PUL/GAL 11 PUL/L
B32X	standard	281	2818	402	4025	1066	10667	64	640	40 PUL/GAL 11 PUL/L

## Max Working Pressure [at 100 F, 38 C]

Flange Ratings	PSI	bar
ANSI 150#	285	19.5
ANSI 300#	740	51
ANSI 600#	1480	102
DIN PN 16	232	16
DIN PN 40	580	40

## Pressure Drop

Model B27X

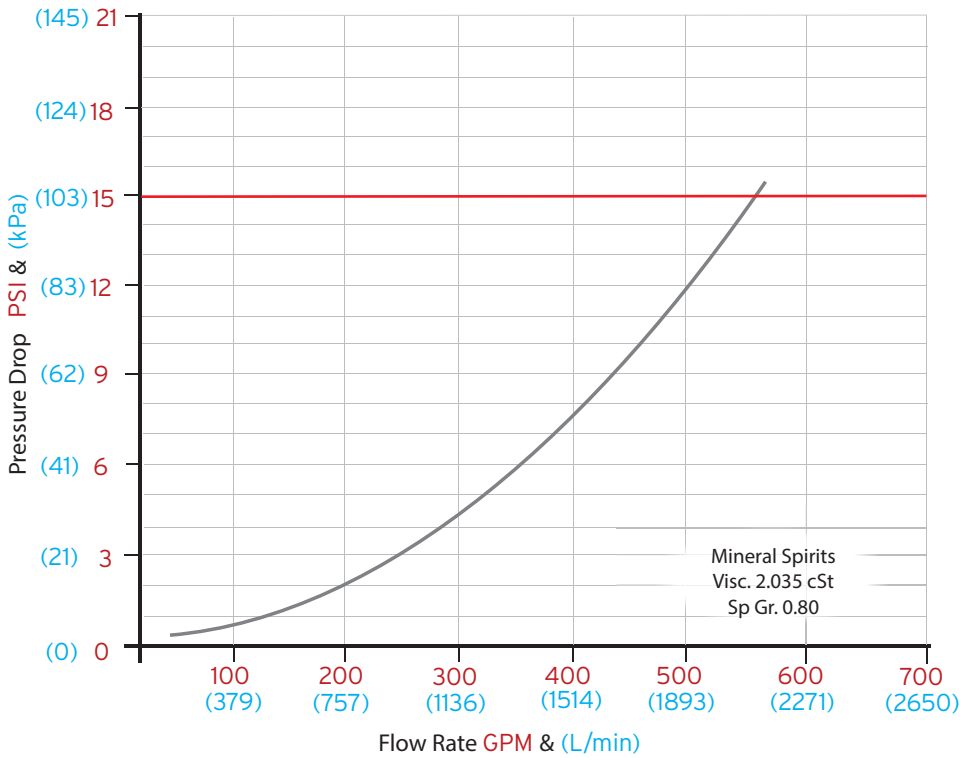

Max Recommended Pressure Drop\*

\*NOTE: This is based upon process conditions

Models B28X & B29X

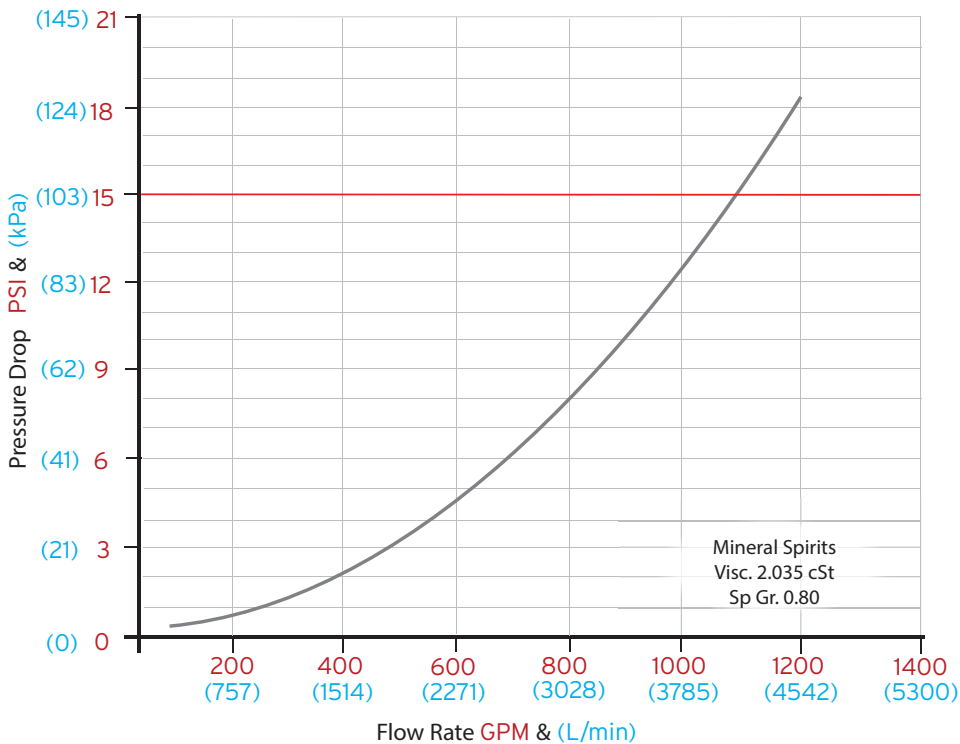

Max Recommended Pressure Drop\*

To convert pressure drop value to the actual process fluid, use the following equation:

$$\Delta PA = (cPA)^{0.25} * (SGA)^{0.75} * \Delta Pm$$

$\Delta PA$  = Pressure Drop on Actual Fluid in PSI  
 $cPA$  = Viscosity of Actual Fluid in cP  
 $SGA$  = Density of Actual Fluid in SG  
 $\Delta Pm$  = Pressure Drop on Mineral Spirits  
 Specific Gravity = 0.80  
 Visc. = 2.035 cSt Mineral Spirits

Models B30X, B31X, & B32X

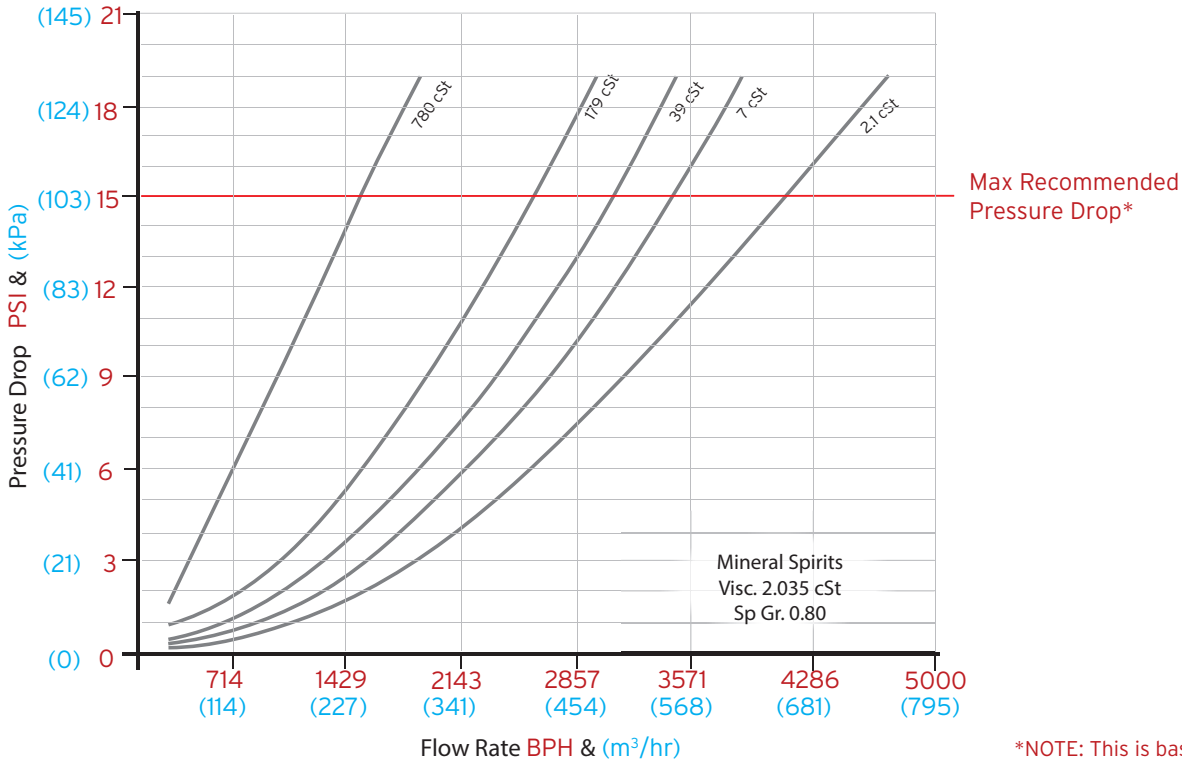

## Preamplifier

Supply voltage:	9 to 30 VDC	Variable voltage pulses:	0 to supply voltage less 5%
Outputs (jumper selectable):	square wave 0 to 5 KHz		70 mA max
5 V powered pulse:	0 - 5 VDC, 20 mA max		

## Wiring Connections

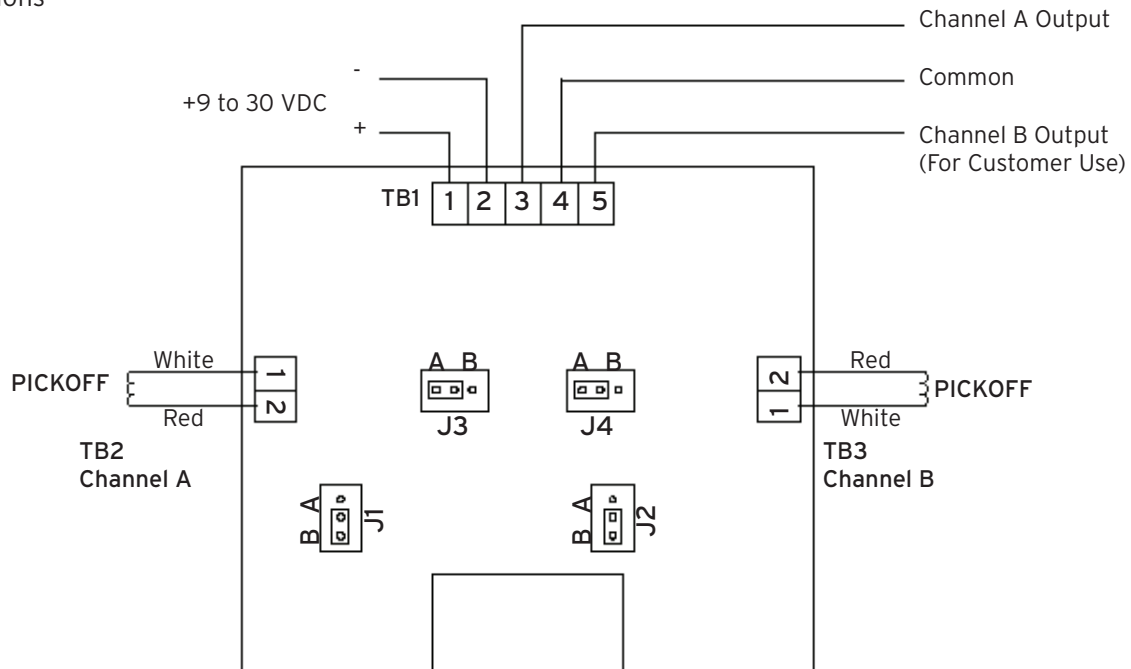

---

## Approvals

### Environmental

- NEMA 4X
- Type 4X
- IP 65
- OIML R117-1 Class H3

### Electromagnetic Emissions & Immunity

- CE European Union (EN 61326)
- OIML R117-1 Class E2
- MID Class E2
- FCC 47 CFR Part 15
- ICES-003 Issue 4

### Weights and Measures

- NTEP (B27X, B28X, B29X)
- Measurement Canada (B27X, B28X, B29X)
- MID/OIML
- China (B27X & B28X)
- Australia NMI
- Malaysia NMIM (B27X, B28X, B29X)
- Singapore (B27X, B28X, B29X)
- India

### Pressure Equipment

- Under the EU Pressure Equipment Directive 2014/68/EU
- Rated as SEP for ANSI 150# and PN 16 versions (For B27X & B28X)
- All other sizes & pressure ratings Rated as CAT 2
- Canadian Registration: All Provinces

### Hazardous Area

- CSA (United States and Canada)
- Class 1, Division 1, Group C, and D Certificate: 2142875, 221162
- standard pick off: -4°F to 167°F, -20°C to 75°C
- high temp pickoff: 14°F to 230°F, -10°C to 110°C

### ATEX

- CE 0359 II 2 G Ex db IIB T6...T4 Certificate: ITS08ATEX 15842X
- standard pick-off: -20°F to 167°F, -29°C to 75°C
- high temp pickoff: -20°F to 230°F, -29°C to 110°C

### IEC Ex

- Ex db IIB T6 - T4 Gb Certificate: IECEx ITS 08.0021X
- standard pick-off: -20°F to 167°F, -29°C to 75°C
- high temp pickoff: -20°F to 230°F, -29°C to 110°C

## Dimensions

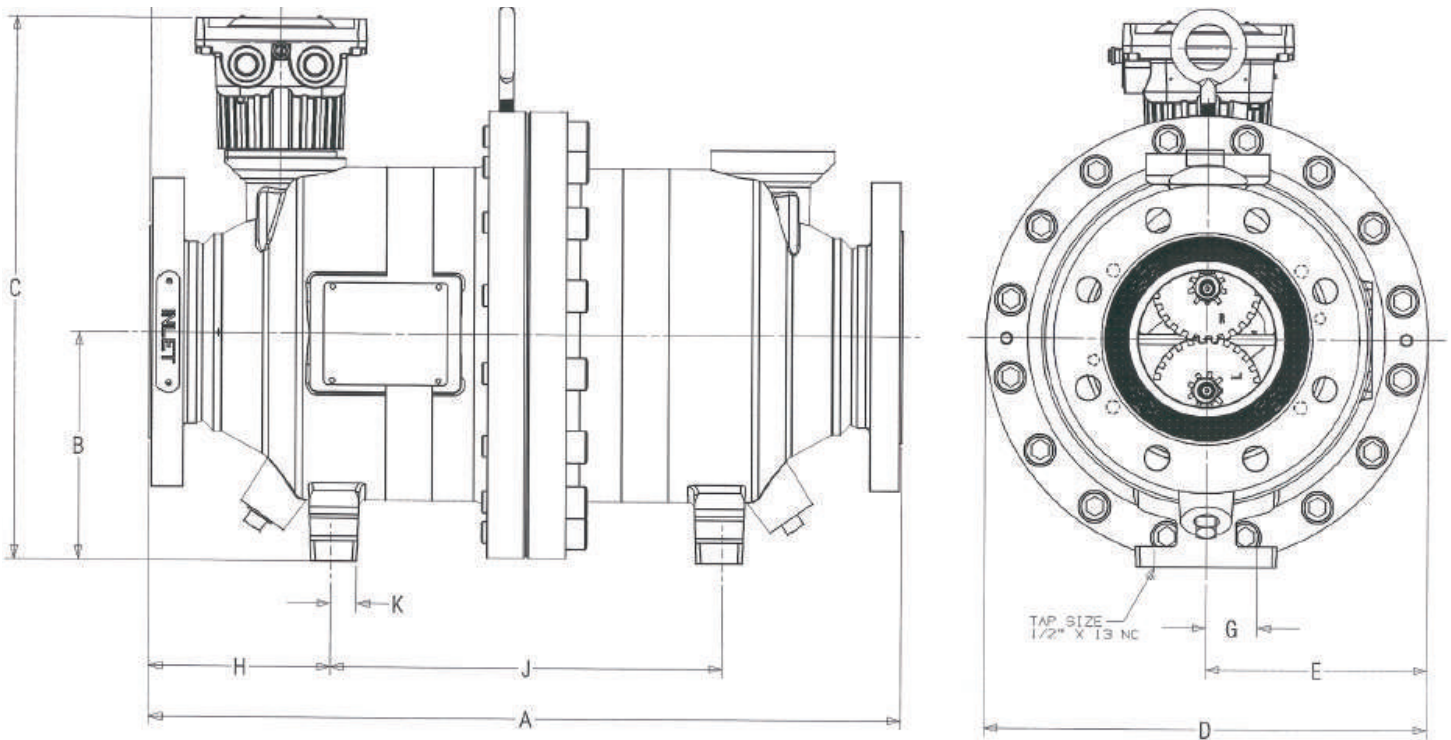

Standard BiRotor Plus Dimensions

Model	Size	Unit	A	B	C	D	E	G	H	J
B27XC	3" ANSI 150#	inch	18	6 1/6	14 13/16	11 1/2	5 3/4	1 3/8	4 3/16	9 5/8
		mm	457	154	376	292	146	35	107	244
	DN80 PN 16	inch	18	6 1/16	14 13/16	11 1/2	5 3/4	1 3/8	4 3/16	9 5/8
		mm	457	154	376	292	146	35	107	244
	3" ANSI 300#	inch	19	6 1/16	14 13/16	11 1/2	5 3/4	1 3/8	4 11/16	9 5/8
		mm	483	154	376	292	146	35	119	244
DN80 PN 40	inch	19	6 1/16	14 13/16	11 1/2	5 3/4	1 3/8	4 11/16	9 5/8	
	mm	483	154	376	292	146	35	119	244	
B28XC	4" ANSI 150#	inch	22	6 5/8	16	13	6 1/2	1 1/2	5 1/4	11 1/2
		mm	559	168	406	330	165	38	133	292
	DN100 PN 16	inch	22	6 5/8	16	13	6 1/2	1 1/2	5 1/4	11 1/2
		mm	559	168	406	330	165	38	133	292
	4" ANSI 300#	inch	23 1/8	6 5/8	16	13	6 1/2	1 1/2	5 15/16	11 1/2
		mm	587	168	406	330	165	38	150	292
	DN100 PN 40	inch	23 1/8	6 5/8	16	13	6 1/2	1 1/2	5 15/16	11 1/2
		mm	587	168	406	330	165	38	150	292
4" ANSI 600#	inch	27	6 7/16	21 1/8	20	10	N/A	N/A	N/A	
	mm	685.8	163.5	536.6	508	254	N/A	N/A	N/A	
B29XC	6" ANSI 150#	inch	24	6 5/8	16	13	6 1/2	1 1/2	6 1/4	11 1/2
		mm	610	168	406	330	165	38	150	292
	DN 150 PN 16	inch	24	6 5/8	16	13	6 1/2	1 1/2	6 1/4	11 1/2
		mm	610	168	406	330	165	38	150	292

Dimensions Cont.

Model	Size	Unit	A	B	C	D	E	G	H	J
B30XC	6" ANSI 150#	inch	40	11 3/4	25 3/16	22 1/8	11 1/16	2 5/8	11 3/8	17 3/16
		mm	1016	298	640	562	281	67	289	436
	6" ANSI 300#	inch	42	11 3/4	25 3/16	22 1/8	11 1/16	2 5/8	11 3/8	17 3/16
		mm	1067	298	640	562	281	67	289	436
	6" ANSI 600#	inch	45	11 3/4	25 3/16	22 3/4	11 3/8	2 5/8	13 15/16	17 1/16
		mm	1143	298	640	578	289	67	354	433
B31XC	8" ANSI 150#	inch	40	11 3/4	25 3/16	22 1/8	11 1/16	2 5/8	11 3/8	17 3/16
		mm	1016	298	640	562	281	67	289	436
	8" ANSI 300#	inch	42	11 3/4	25 3/16	22 1/8	11 1/16	2 5/8	11 3/8	17 3/16
		mm	1067	298	640	562	281	67	289	436
B32XC	10" ANSI 150#	inch	40	11 3/4	25 3/16	22 1/8	11 1/16	2 5/8	11 3/8	17 3/16
		mm	1016	298	640	562	281	67	289	436
	10" ANSI 300#	inch	42	11 3/4	25 3/16	22 1/8	11 1/16	2 5/8	11 3/8	17 3/16
		mm	1067	298	640	562	281	67	289	436

Special 'B' Rev BiRotor Plus Dimensions ( Available upon request )

Model	Size	Unit	A	B	C	D	E	G	H	J	
B27XB	3" ANSI 150#	inch	16 3/4	6 1/6	14 13/16	11 1/2	5 3/4	1 3/8	3 9/16	9 5/8	
		mm	425	154	376	292	146	35	90	244	
	DN80 PN 16	inch	16 3/4	6 1/16	14 13/16	11 1/2	5 3/4	1 3/8	3 9/16	9 5/8	
		mm	425	154	376	292	146	35	90	244	
	3" ANSI 300#	inch	17 1/8	6 1/16	14 13/16	11 1/2	5 3/4	1 3/8	3 3/4	9 5/8	
		mm	435	154	376	292	146	35	95	244	
	DN80 PN 40	inch	17 1/8	6 1/16	14 13/16	11 1/2	5 3/4	1 3/8	3 3/4	9 5/8	
		mm	435	154	376	292	146	35	95	244	
	B28XB	4" ANSI 150#	inch	20	6 5/8	16	13	6 1/2	1 1/2	4 1/4	11 1/2
			mm	508	168	406	330	165	38	108	292
		DN100 PN 16	inch	20	6 5/8	16	13	6 1/2	1 1/2	4 1/4	11 1/2
			mm	508	168	406	330	165	38	108	292
4" ANSI 300#		inch	20 5/8	6 5/8	16	13	6 1/2	1 1/2	4 9/16	11 1/2	
		mm	524	168	406	330	165	38	116	292	
DN100 PN 40		inch	20 5/8	6 5/8	16	13	6 1/2	1 1/2	4 9/16	11 1/2	
		mm	524	168	406	330	165	38	116	292	

## Materials Housing

Meter Housing: ASTM A352 LCB or  
 ASTM A 216 WCB  
 ASTM A 516 GR 70  
 Connection Flanges: ASTM A 105 Carbon Steel or  
 ASTM A 350 LF2  
 Sensor Housing: ASTM A 479  
 304 Stainless Steel

## Materials Measuring Unit

End Plates and Body: A 356 T6 Cast Aluminium  
 Rotors: ALCO 319 Cast Aluminium Hard Coat  
 anodized  
 Rotor Shafts: 17-4 PH Stainless Steel  
 Timing Gears: 17-4 PH Stainless Steel (Heat Treated)  
 Bearings: Hybrid Ceramic  
 Elastomers: Low Swell Nitrile, Viton®,  
 or Fluorosilicon are standard  
 UMB Housing: A356 T6 Cast Aluminium [non wetted  
 component]

## Shipping weights

Model	Size	Unit	Weight
B 27 X	3" ANSI 150# DN80 PN16	lb	120
		kg	55
	3" ANSI 300# DN80 PN 40	lb	125
		kg	57
B 28 X	4" ANSI 150# DN100 PN16	lb	180
		kg	82
	4" ANSI 300# DN100 PN40	lb	192
		kg	87
	4" ANSI 600#	lb	800
		kg	363
B 29 X	6" ANSI 150# DN150 PN 16	lb	241
		kg	109
B 30 X	6" ANSI 150#	lb	899
		kg	407
	6" ANSI 300#	lb	915
		kg	415
	6" ANSI 600#	lb	1500
		kg	680
B 31 X	8" ANSI 150#	lb	1002
		kg	454
	8" ANSI 300#	lb	1053
		kg	478
B 32 X	10" ANSI 150#	lb	1025
		kg	464
	10" ANSI 300#	lb	1114
		kg	505

### Brodie International

P.O. Box 450 (30459-0450)  
 19267 Highway 301 North  
 Statesboro, GA 30461  
 USA

Phone: +1 (912) 489-0200  
 Fax: +1 (912) 489-0294