

ROTARY ACTUATOR

SPECIFICATION DATA



General

The OM series is equipped with standard On-Off or modulating (4~20mA, 1~5V, or 0(2)~10V select by DIP-switch) control quarter-turn electric actuator.

The OM series can also provide feedback output signal: Dry contact for On-Off version; 0~5V, 0~10V, 4~20mA (selected by DIP- switch) for modulating version, Auxiliary Switch is optional.

FEATURES

- For On-Off or Modulating Control
- Manual override non-clutch design. Manual operation can be operated without any lever, clutch or brake upon power voltage.
- Irreversible worm gear.
- Visual mechanical position indicator for accurate visual reference of valve position.
- Anti-condensation heater and 2 aux. limit switches on standard model
- Enclosure IP67

SPECIFICATIONS

Power Supply	220Vac, 50/60 Hz
Running time	See table (1)
Travel Angle	90° ± 5°
Input (Modulating)	4~20mA, 1~5V, or 0(2)~10V select by DIP-switch
Feedback (Modulating)	4~20mA or 0(2)~10V select by DIP-switch
Enclosure	IP67 Waterproof
Ambient Temperature	-30°C to +65°C
Indicator	Continuous Position Indicator
Manual Override	Non-clutch design
Worm Gear	Permanently lubricated and self locking
Space Heater	15W 220V Anti-condensation
Material	Aluminum Alloy
External Coating	Dry powder coating
Stall Protection	Built-in thermal protection
	Cut off at 125 ± 5°C
	Reset at 95 ± 5°C

Table (1) Actuator Data

OS# On-Off	OS# Modulating	Max Torque (Nm)	Run Time at 60Hz (sec)	Power Consumption (Watts)	Manual Override	Weight (Kg)
OM-1	OM-P1	35	12	10		2
OM-2	OM-P2	90	15	40	Hand-wheel	11
OM-3	OM-P3	150	22	40	Hand-wheel	11
OM-4	OM-P4	400	16	120	Hand-wheel	22
OM-5	OM-P5	500	22	120	Hand-wheel	22
OM-6	OM-P6	650	28	120	Hand-wheel	22
OM-7	OM-P7	1000	46	180	Hand-wheel	36
OM-8	OM-P8	1500	46	220	Hand-wheel	36
OM-9	OM-P9	2000	58	180	Hand-wheel	56
OM-10	OM-P10	2500	58	220	Hand-wheel	56
OM-11	OM-P11	3000	58	250	Hand-wheel	56
OM-12	OM-P12	3500	58	300	Hand-wheel	56

Table (1a) Actuator Dimensions (mm)

OM-1

OS#	A	B	C	D	E	F	G	H	I	J	K	L _{max}	M	N	S	Flange Type
OM-1	114	8	45°	155	15	36	m5	4	m6	6	50	14	19	2	½ PS	F03/ F05

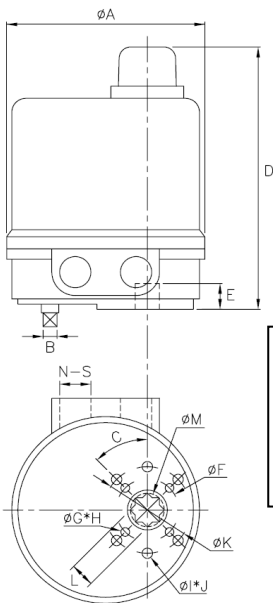

- Option: (1) L=11, M=15
(2) L=9, M=12
- With Modulating Card D=185
- No mechanical stops

Table (1b) Actuator Dimensions (mm)

OM-2 to OM-6

OS#	A	B	C	D	E	F	G _{Max}	H	I	M	N	S	Flange Type
OM-2&3	203	326	180	255	30	123	22	70	m8	4	2	½ PS	F07
OM-4,5,6	290	394	217	317	40	194	35	102	m10	4	2	½ PS	F10

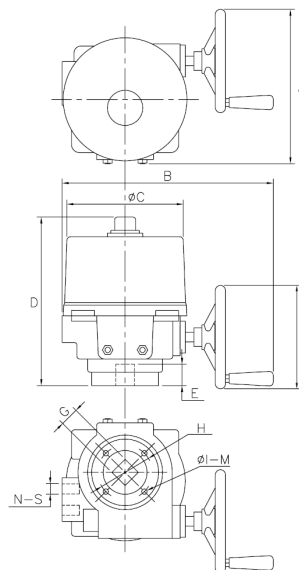

Table (1c) Actuator Dimensions (mm)

OM-7 to OM-8

OS#	A	B	C	D	E	F	G	H	I	J	K	L*2	M max	N	S	Flange Type
OM-7 OM-8	385	340	217	420	60	295	140	45°	m16	4	180	10	35	2	1/2 PS	F14

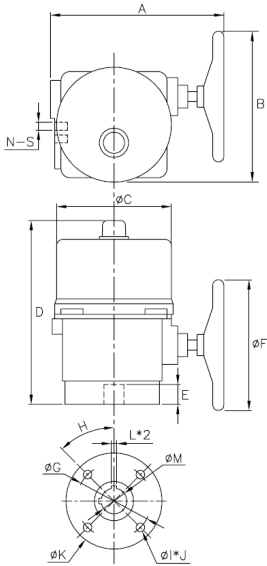
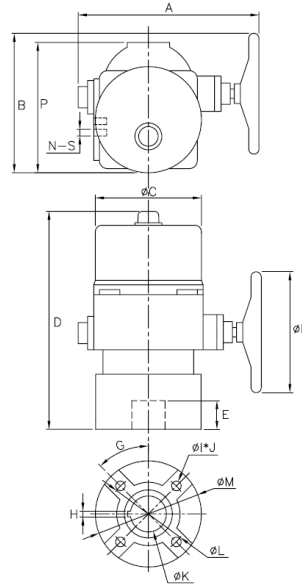

Table (1d) Actuator Dimensions (mm)

OM-9 to OM-12

OS#	A	B	C	D	E	F	G	H	I	J	K	L	M	P	N	S	Flange Type
OM-9 to OM-12	470	350	260	590	100	395	45°	12	m20	4	75	165	221	360	2	1/2 PS	F16



WIRING DIAGRAM FOR ON/OFF

[OM-1 & OM-A 110V / 220V AC 1-PH]

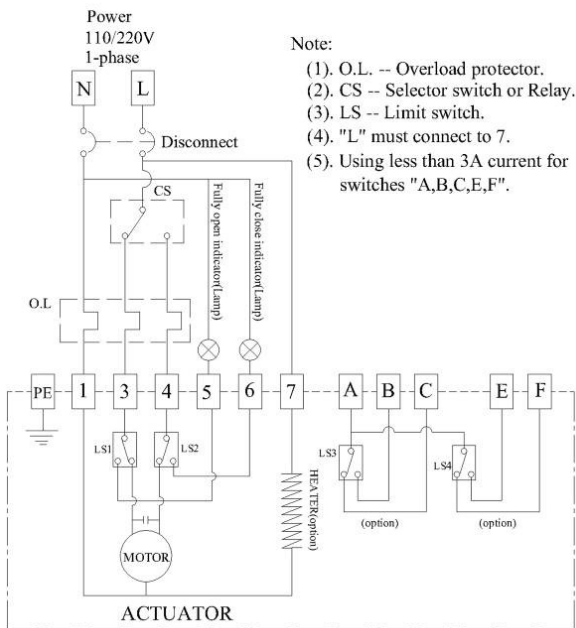

- Note:
- (1). O.L. -- Overload protector.
 - (2). CS -- Selector switch or Relay.
 - (3). LS -- Limit switch.
 - (4). "L" must connect to 7.
 - (5). Using less than 3A current for switches "A,B,C,E,F".

[BM-2,OM-2 ~ OM-12 110V / 220V AC 1-PH]

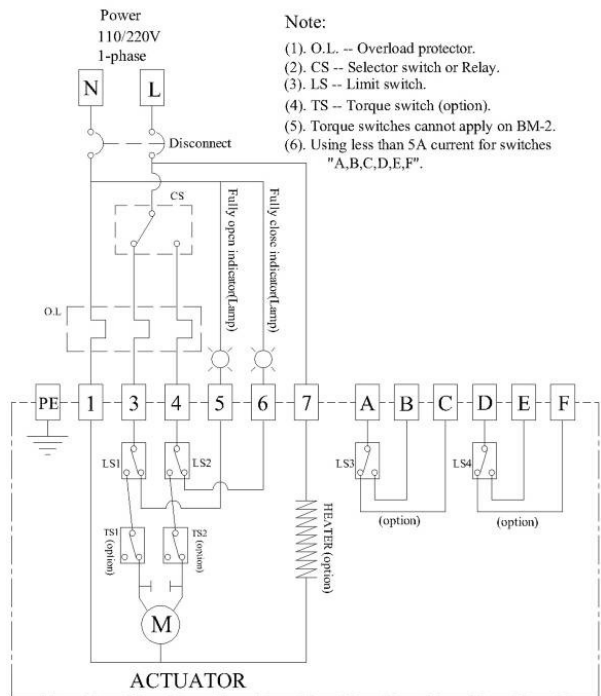

- Note:
- (1). O.L. -- Overload protector.
 - (2). CS -- Selector switch or Relay.
 - (3). LS -- Limit switch.
 - (4). TS -- Torque switch (option).
 - (5). Torque switches cannot apply on BM-2.
 - (6). Using less than 5A current for switches "A,B,C,D,E,F".

TROUBLE SHOOTING

Conditions	Possibilities	Solution
Motor does not operate	1. Is the supplied power and voltage correct?	1. Check by meter.
	2. Any blisters on the capacitor?	2. If so, replace.
	3. Are the gear train free?	3. Remove motor and check.
Motor stops running	1. Is the power supply short circuited?	1. Check wiring.
	2. Any foreign objects in flow stream?	2. Check for obstructions.
Unable to fully open/close	1. Loose/Misalign cam?	1. Adjust/Tighten using spanner.
	2. Bent valve stem?	2. Replace valve stem.
	3. Mechanical stop adjustment incorrect?	3. Check position of stops.
Abnormal control for operating two or more actuators simultaneously.	Controlling circuit connects in tandem or parallel.	Refer to the wiring diagram.
Motor overheats	1. Is the voltage correct?	1. Check by meter.
	2. Is valve too tight to operate?	2. Replace valve.
	3. High duty working frequency?	3. Check duty cycle.
	4. Is motor stem bearing or blinding?	4. Replace the blinding parts.
Occasional on/off actuator failure.	Simultaneous input power on/off.	Check if the selectable switch is normal.

INSTALLATION

***Remove power before the cover is dismantled!
The actuator must be handled with the utmost care when the cover is removed and the power connected!***

ELECTRIC WIRING

Note:

Electric wiring must be carried out by qualified personnel only!

Wiring diagram is also shown on the label of top cover.

Honeywell

Automation and Control Solutions

Honeywell Taiwan Ltd
10F, 168 Lien Cheng Road
Chung Ho City, Taipei County, Taiwan
Phone: +886-2-22451000
Fax: +886-2-22453241

Subject to change without notice.