

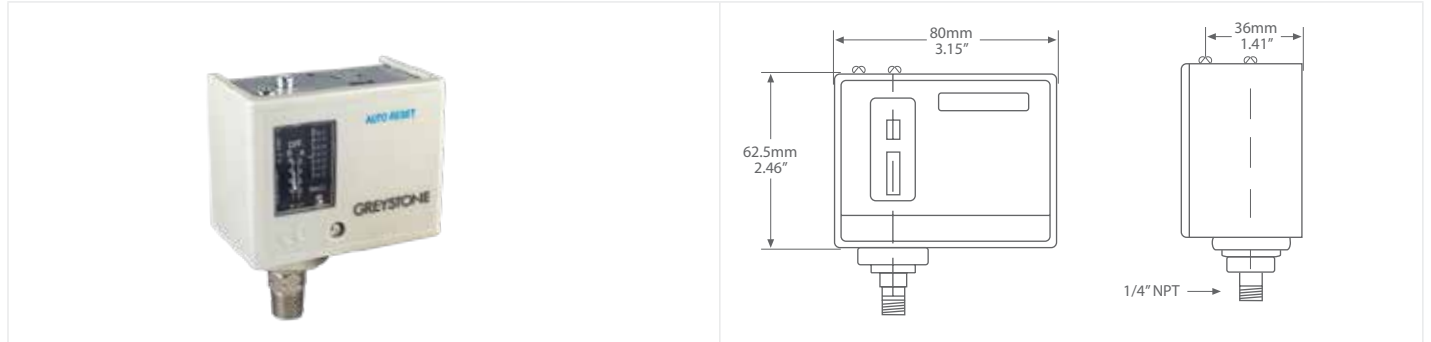

## GAUGE PRESSURE SWITCH



### GLPS-G SERIES

## PRODUCT DESCRIPTION

The GLPS-G pressure switch is a cost effective pressure monitoring solutions for liquids and non aggressive gases. The compact design and rugged construction makes the GLPS-G suitable for monitoring pumps, chillers, valves, etc. The unit has an adjustable setpoint with adjustable differential and comes complete with a dial to show the liquid pressure.

## ORDERING INFORMATION

GLPS-G

## SPECIFICATIONS

RANGE	-0.5 to 6 Bar (-7.25 to 87 PSI)
MAX WORKING PRESSURE	16.5 Bar (239 PSI)
DIFFERENTIAL	0.6 to 4 Bar (8.7 to 58 PSI)
FACTORY SETTINGS	Off: 3 Bar (43.5 PSI) On: 2 Bar (29 PSI)
RESET	Automatic
PRESSURE CONNECTION	1/4" NPT
CONTACT RATING	See chart below
FLUID TEMPERATURE	-20 to 120°C (-4 to 248°F)
PROTECTION	IP44
DIMENSIONS	80mm W x 62.5mm H x 50mm D (3.15" x 2.46" x 1.96")
APPROVALS	CE

## CONTACT FUNCTION

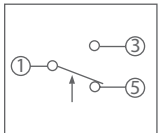

1	Common Terminal
3	Close on Pressure Decrease
5	Close on Pressure Increase

↑: Pressure rise.

## CONTACT RATING

		RATED VOLTAGE (V)		
		125 VAC	250 VAC	24 VDC
RATED AMPS (A)	Non-Inductive Current	20A	10A	10A
	Inductive Current	Full Load	8A	8A
		Locked Rotor	72A	

## CONNECTION AND INSTALLATION

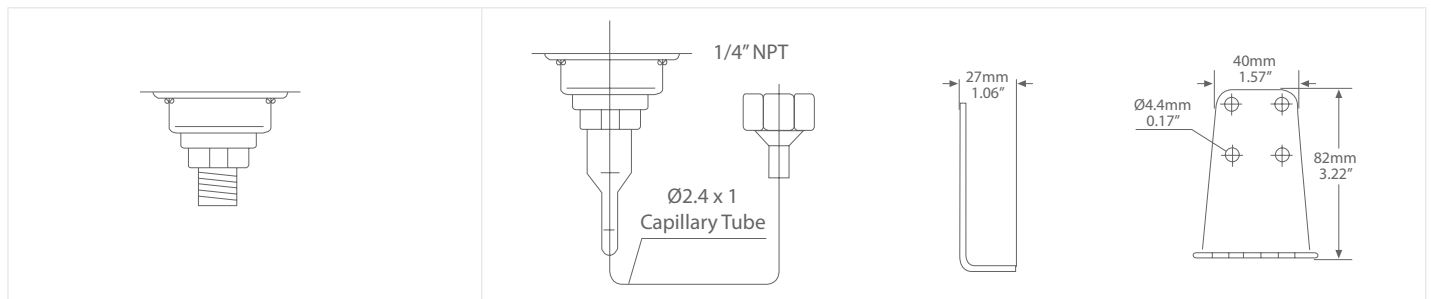

1/4" NPT CONNECTION

MOUNTING PLATE



Greystone Energy Systems, Inc.  
150 English Drive, Moncton,  
New Brunswick, Canada E1E 4G7

Ph: +1 (506) 853-3057 Fax: +1 (506) 853-6014  
North America: 1-800-561-5611  
E-mail: mail@greystoneenergy.com