



48 x 48mm

**Features :**

- 4 + 4 Digits, 7 Segment LED Dual Display
- Universal Input
- ON - OFF / PID Control
- °C / °F Selectable
- Heat Cool PID
- Ramp Soak
- Soft Start
- RS485 Communication MODBUS RTU Protocol

Certifications :

**Display Specifications**

Digits	4 + 4 Digits, 7 Segment LED Dual Display Height of Upper Display : 10mm Height of Lower Display : 07mm
LED Indications	1 : Main output, 2, 3 : Alarm output, M : Manual output, T : Tune.

**Input Specifications**

Inputs	Thermocouple (J, K, T, R, S, C, E, B, N, L, U, W, Platinel II), RTD (PT100) Signal inputs (-5 to 56mV, 0 to 10V, 0 to 20mA DC) (Programmable Scale Type)
Resolution	1 / 0.1° for TC / RTD only ( Fixed 1° resolution for R & S type TC) Decimal point position selectable: 1 / 0.1 / 0.01 / 0.001 for analog input
Indication Accuracy	For TC inputs : 0.25% of F.S. ±1° For R & S type TC inputs : 0.5% of F.S. ±2° (20 min of warm up time for TC inputs) For RTD input : 0.1% of F.S. ±1° For Analog input : ±0.5%, ±1 digit (F.S. = Full Scale)
Temperature Unit	°C / °F Selectable
Input Filter (FTC)	1 to 99sec, OFF
Sampling time	200 ms

**Output Specifications**

<b>Control Output</b> ( Optional )	1
Contact Rating (SPST)	5A @ 230V AC / 30V DC, resistive
SSR Drive (Voltage Pulse)	18V DC, 20mA
Current	4 to 20mA DC (loop impedance : 500Ω max.)
Voltage	0 to 10V DC (load resistance : 10KΩ min.)
<b>Auxiliary Output</b> ( Optional )	2
Contact Rating (SPST)	5A @ 230V AC / 30V DC
SSR Drive	12V DC, 20mA
<b>Retransmission</b>	
Current	4 to 20mA DC (loop impedance : 500Ω max)
Voltage	0 to 10V DC (load resistance : 10KΩ min.)
Update Rate	100 msec

**Functional Specifications**

Control Action	1) PID 2) ON-OFF
Proportional Band (P)	0.0 to 400.0°
Integral Time (I)	0 to 3600 sec
Derivative Time (D)	0 to 200 sec
Cycle Time	0.1 to 100.0 sec
Hysteresis Width	0.1 to 99.9°
Manual Reset Value	-99.9 to 99.9°
<b>Heat Cool PID</b>	
Control Action	PID / ON-OFF
Cycle Time	0.1 to 100 sec
Proportional Gain	0.0 to 400.0°
Deadband	Programmable from setpoint low limit to setpoint high limit
<b>Alarms</b>	
Modes	Deviation high / low, Absolute high / low, Band, sensor Break
Hysteresis	0.1 to 99.9°
<b>Ramp Soak</b>	
Ramp Rate	1 to 9999° / hr
Soak Time	0 to 1440 min
Soft Start Time	0 to 999 min

**Auxiliary Supply Specifications**

Supply Voltage	90 to 270V AC / DC (50 / 60Hz)
Power Consumption	5 VA max @ 230V AC

**Environmental Specifications**

Temperature	Operating : 0 to 50°C (32 to 122°F) Storage : -20 to 75°C (-4 to 167°F)
Humidity (non - condensing)	85% RH

**Mechanical Specifications**

Mounting	Panel Mount
Weight	195 gms

Optional Specifications

SERIAL COMMUNICATION	
Interface standard	RS485
Communication address	1 to 99, maximum of 32 units per line
Transmission mode	Half duplex
Transmission protocol	MODBUS RTU
Transmission distance	500 m maximum
Transmission speed	9600, 4800, 2400, 1200, 600, 300 bits / sec
Parity	Non, Odd, even, Mark, Space
Stop bits	1 or 2
Response Time	100 ms (Max and independent of boud rate)

Dimensions

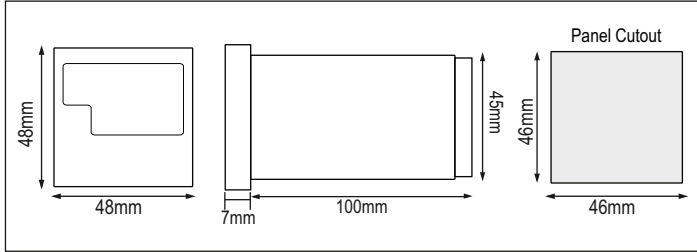

Terminal Connections

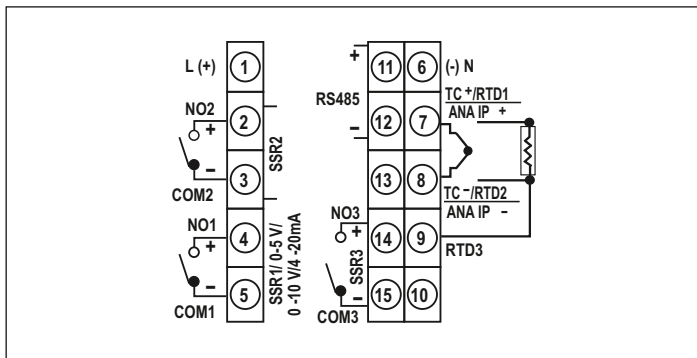

	Cable Size (AWG): 16-13 ; Stud Hole for Lug (inch): 0.137 ; Tightening Torque (Lb-inch): 7
	Cable Size (mm²): 1.5-2.5 ; Stud Hole for Lug (mm): 3.5 ; Tightening Torque (N-m): 0.8

Accessories ( Optional )

Standard SELEC accessories that can be used with this product.

Adapter plate
1) AP7248 : Plastic adapter plate, used to mount 1 / 16 DIN (cutout size 48 x 48) Instrument into existing (72 x 72) cutout size.
2) AP9648 : Plastic adapter plate, used to mount 1 / 16 DIN (cutout size 48 x 48) Instrument into existing (96 x 96) cutout size.
3) AP4896-4848-G-C : Plastic adapter plate, used to mount 1 / 16 DIN (cutout size 48 x 48) Instrument into existing (48 x 96) cutout size.

Mounting Accessories (Supplied with units)

48 X 48 Collar clamp	ACL4802
----------------------	---------

Compliance

Applicable EMI / EMC Standards		
Product Standard : IEC 61326-1		
Category		Standards Compliance
ESD Immunity	IEC 61000-4-2	Level III
Surge Immunity	IEC 61000-4-5	+/- 2 kV common mode, +/- 1 kV differential mode
Radiated Susceptibility	IEC 61000-4-3	Level III, 80 to 1000MHz Level II, 1.4GHz to 2GHz Level I, 2GHz to 2.7GHz
Conducted Susceptibility	IEC 61000-4-6	Level II
Voltage Dips and Interruptions	IEC 61000-4-11	<b>Dips</b> : 0% residual voltage / 1 cycle (Criteria B), 40% residual voltage / 10 cycles 50Hz / 12 cycles 60Hz (Criteria C) 70% residual voltage / 25 cycles 50Hz / 30 cycles 60Hz (Criteria C) <b>Interruptions</b> : 0% residual voltage / 250 cycles 50Hz / 300 cycles 60Hz (Criteria C)
Conducted Emission	CISPR-11	
Radiated Emission	CISPR-11	
Electrical Fast Transient	IEC 61000-4-4	Level III

Ordering Information

PRODUCT CODE	OUTPUT 1	OUTPUT 2	OUTPUT 3		SUPPLY VOLTAGE	CERTIFICATION
			RELAY / SSR	COMMUNICATION (RS485)		
PID500-0-0-01	RELAY	RELAY	RELAY	--	90-270V AC / DC	--
PID500-0-0-01 V2-CE	RELAY	RELAY	RELAY	--	90-270V AC / DC	CE
PID500-0-0-04	RELAY	RELAY	RELAY	YES	90-270V AC / DC	--
PID500-0-0-04 V2-CE	RELAY	RELAY	RELAY	YES	90-270V AC / DC	CE
PID500-2-0-01	4-20mA	RELAY	RELAY	--	90-270V AC / DC	--
PID500-2-0-01 V2-CE	4-20mA	RELAY	RELAY	--	90-270V AC / DC	CE
PID500-1-0-01	SSR	RELAY	RELAY	--	90-270V AC / DC	--
PID500-1-0-01 V2-CE	SSR	RELAY	RELAY	--	90-270V AC / DC	CE
PID500-1-0-00	SSR	RELAY	NA	--	90-270V AC / DC	--
PID500-1-0-00 V2-CE	SSR	RELAY	NA	--	90-270V AC / DC	CE
PID500-2-0-04	4-20mA	RELAY	RELAY	YES	90-270V AC / DC	--
PID500-2-0-04 V2-CE	4-20mA	RELAY	RELAY	YES	90-270V AC / DC	CE
PID500-3-0-00	0-10V	RELAY	RELAY	--	90-270V AC / DC	--
PID500-3-0-00 V2-CE	0-10V	RELAY	RELAY	--	90-270V AC / DC	CE
PID500-1-1-05-CU	SSR	SSR	SSR	YES	90-270V AC / DC	CE, UL

Input Sensor Ranges (For TC / RTD Inputs)

Sensor type	Resolution	Ranges	
		1	0.1
PT100	°C	-150 to 850	-150 to 850
	°F	-238 to 1562	-199 to 999
J	°C	-199 to 750	-199 to 750
	°F	-328 to 1382	-199 to 999
K	°C	-199 to 1350	-199 to 999
	°F	-328 to 2462	-199 to 999
T	°C	-199 to 400	-199 to 400
	°F	-328 to 750	-199 to 750
R & S	°C	0 to 1750	N/A
	°F	32 to 3182	N/A