

AKM 115S F152: High-speed rotary actuator with SAUTER Universal Technology (SUT) for ball valve

How energy efficiency is improved

Automatic adaptation to ball valve, electronic cut-off, precise activation and high energy efficiency with minimal operating noise

Features

- For actuating 2- and 3-way regulating ball valves (VKR and BKR series)
- For controllers with constant output (0...10 V/4...20 mA) or switching output (2-/3-point control)
- For ball valves up to DN 50
- Fitted to ball valve without the use of tools
- Brushless motor with electronic activation and cut-out
- Intelligent adaptation of angle of rotation, incl. feedback adjustment
- Electronic force-dependent cut-off
- Direction of rotation selected with DIP switch
- Pulse length correction in 3-point operation, i.e. internal adjustment of start-up time
- Gear unit can be disengaged to position the ball valve manually (using a lever)
- Maintenance-free
- Free configuration using the CASE Drive PC tool
- Bracket and bayonet ring made of glass-fibre-reinforced plastic for fitting onto ball valve



AKM115SF152



Technical data

Power supply		
Power supply 24 V~		±20%, 50...60 Hz
Power supply 24 V=		-10%...20%
Power consumption		6.5 W, 9 VA (at nominal voltage)
Parameters		
	Torque	8 Nm
	Noise during operation (unloaded)	< 49 dB(A)
	Response time	10 ms
	Angle of rotation	90°
	Running time	6 s
	Characteristic	linear
Positioner		
	Positioning signal y	0...10 V/2...10 V, R _i = 100 kΩ, 0...20 mA/4...20 mA, R _i = 500 kΩ
	Positional feedback y ₀	0...10 V; load > 10 kΩ
	Starting point U ₀	0 or 10 V or 2 or 10 V
	Starting point I ₀	0 or 20 mA or 4 or 20 mA
	Control span ΔU	10 V
	Switching range X _{sh}	100 mV
	Control span ΔI	20 mA
	Switching range X _{sh}	0.1 mA
Ambient conditions		
	Operating temperature	-20...55 °C
	Temperature of medium ¹⁾	Max. 100 °C
	Storage and transport temperature	-30...65 °C
	Admissible ambient humidity	5...85% rh, no condensation
Construction		
	Fitting	Vertically upright to horizontal
	Dimensions W x H x D	70 × 138 × 127 mm
	Weight	0.7 kg
	Housing	Lower section black, upper section yellow
	Housing material	Fire-retardant plastic

¹⁾ Use the appropriate accessory when temperature of the medium is > 100 °C



Power cable	1.2 m, 6 × 0.5 mm ²
-------------	--------------------------------

Standards and directives

	Type of protection	IP 54 (EN 60529), horizontal
	Protection class	III (EN 60730)
CE conformity as per	EMC directive 2004/108/EC	EN 61000-6-1, EN 61000-6-2 EN 61000-6-3, EN 61000-6-4

Overview of types

Type	Properties
AKM115SF152	High-speed rotary actuator with SAUTER Universal Technology for ball valve

Accessories

Type	Description
0313529001	Split-range unit for adjusting sequences, fitted in separate junction box
0372459102	External switching, 24 V version for parallel operation with A*M 1** or drives with limit switch, incl. junction box
0372462001	CASE Drives PC tool for configuring the drives by computer
0510420001	Adaptor required when temperature of the medium > 100 °C
0510240011	Adaptor required when temperature of the medium < 5 °C

Description of operation

Depending on the type of connection (see connection diagram), the actuator can be used as a continuous 0...10 V or 4...20 mA, 2-point (OPEN/CLOSE) or 3-point actuator (OPEN/STOP/CLOSE) with an intermediate position.

The AKM 115 is combined with ball valves that have an equal-percentage basic characteristic like the VKR or BKR.

The manual adjustment is performed by releasing the gear unit (slide switch beside the connection cable) and turning it with the lever. The actuator position can be seen.

Note: After manually adjusting the slide switch, put it back into its original position (engage gear unit).

Intended use

This product is only suitable for the purpose intended by the manufacturer, as described in the "Description of operation" section.

All related product documents must also be adhered to. Changing or converting the product is not admissible.

Connection as 2-point actuator via the 6-wire connection cable

This OPEN/CLOSE activation is performed via the switch cable of the preferred direction. The actuator is connected to the voltage via the supply cables and the cables for the direction of rotation, MM, LS and O1. The LS and O1 cables are connected together. The actuator turns in the anti-clockwise direction, viewing the spindle adaptor from the actuator, to end position 1 (anti-clockwise direction to 100% angle of rotation), and in the process the control passage of the ball valve is opened. When the voltage is also applied to cable O2, the actuator turns in the clockwise direction to end position 2 (clockwise direction to 0% angle of rotation) and closes the ball valve. When the voltage is switched off at cable O2 the actuator returns to the opposing end position 1 (anti-clockwise direction to 100% angle of rotation) and the control passage of the ball valve is opened fully again. In the end positions (limit stop through angle-of-rotation limit, max. angle of rotation of 95° reached) or in the case of an overload, the electronic motor cut-off is activated (no limit switches).

The direction of rotation is determined by DIP switch 1. If this is left in position 0, the actuator behaves as described above. If the DIP switch is put into position 1, the end positions are swapped - end position 1 becomes end position 2, and vice versa.

The unused wires must not be connected or come into contact with other wires. Therefore, the unused wires must be insulated individually.

Connection as 3-point control unit via the 6-wire connection cable

The actuator is connected to the power supply, after which the ball valve actuator can be moved to any position by connecting the voltage to cable O1 or cable O2. Direction of rotation (viewing the spindle of the ball valve from the actuator):

- The stem turns in the clockwise direction, with voltage on cable O1, and closes the ball valve.
- The stem turns in the anti-clockwise direction, with the voltage on cable O2.

In the end positions (limit stop in actuator, max. angle of rotation of 95° reached) or in the case of an overload, the electronic motor cut-off is activated (no limit switches). Direction of rotation changed by transposing the connections.

The direction of rotation can only be selected via DIP switch 1; if this is left in position 0, the actuator behaves as described above. If the DIP switch is put into position 1, the directions change their positions - direction 1 becomes direction 2, and vice versa.

The unused wires must not be connected or come into contact with other wires. Therefore, the unused wires must be insulated individually.

Connection for control voltage 0...10 V or 4...20 mA via the 6-wire connection cable

The built-in positioner controls the actuator depending on controller's output signal y.

Direction of rotation (viewing the spindle of the ball valve from the actuator):

Direction of operation 1:

When the positioning signal is increasing, the spindle adaptor turns in the anti-clockwise direction and opens the control passage of the ball valve.

Direction of operation 2:

When the positioning signal is increasing, the spindle adaptor turns in the clockwise direction and closes the control passage of the ball valve.

The direction of operation can only be selected via DIP switch 1; if this is left in position 0, the actuator behaves as described above. If the DIP switch is put into position 1, the direction of operation changes its direction - direction 1 becomes direction 2, and vice versa.

As the starting point and the control span are defined as fixed values, a split-range unit is available (accessory) for setting partial ranges.

Initialisation and feedback signal

The actuator initialises itself autonomously when it is connected. Once a voltage is applied to the actuator for the first time, the actuator moves to the first limit stop. Then it moves to the second stop and the value is detected and saved via a travel measurement system. The control signal and the feedback are adapted to this effective path. In case of a power failure or the removal of the power supply, no re-initialisation is carried out. The values remain saved.

For a re-initialisation, the actuator must be connected to the power supply. An initialisation is triggered by activating the manual adjuster twice within 4 s.

During initialisation, the feedback signal is inactive or equal to the value "0". The re-initialisation is only valid when the whole process is complete. Activating the manual adjuster again interrupts this process.

If the actuator detects jamming, it reports this by setting the feedback signal to 0 V after about 90 s.

During this time, the actuator tries to overcome the jamming. If the jamming can be overcome, the normal control function is activated again, and the feedback signal is restored.

With 2-point or 3-point control, the same initialisation is performed. Afterwards, the feedback signal is active.

When control signal 0...10 V is interrupted and direction of operation 1 is selected via DIP switch 1, the ball valve is closed completely (0% position).

Additional technical data

The upper half of the lower section of the housing contains the DC motor and the SUT-II electronics. The bottom half of the lower section of the housing contains the maintenance-free gear unit, the gear-release lever and the spindle adapter.

Power consumption at nominal voltage

Type	Running time [s]	Status	Active power P [W]	Apparent power S [VA]
AKM115F152	6	Operation	6.5	
		Standstill ²⁾	1	
		Sizing		9



Coding switch

AKM115SF152 90°	S1	S2	S3
	Direction of operation	Select current or voltage	Increase working range
Direction of operation 1 ○	OFF		

²⁾ Load-free

AKM115SF152 90°	S1	S2	S3
Direction of operation 2 \odot	ON		
Voltage		OFF	
Current		ON	
Input 03 Voltage 0...10 V / Current 0...20 mA			OFF
Input 03 Voltage 2...10 V / Current 4...20 mA			ON

Characteristic

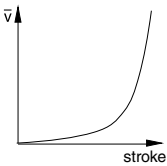
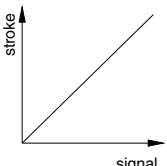
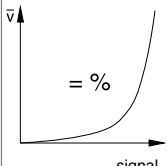
		
VKR/BKR Equal-percentage	Rotary actuator AKM Linear	Control unit AKM + VKR/BKR Equal-percentage
		

Split-range unit, accessory 0361529001

Starting point U_0 and control span ΔU can be set with the potentiometer. In this way, several control units can be operated in sequence or cascade by the control signal of the controller. The input signal (partial range) is amplified into an output signal of 0...10V. This accessory cannot be built into the actuator but must be externally housed in an electrical junction box.

CASE Drives PC Tool, accessory 0372462001

CASE Drives allows you to set and read the actuator parameters on site. The connection is via a serial port on the PC (laptop) and a socket on the actuator. The set consists of: The software including installation and operating manual, fitting instructions, connection plug, cable (1.2 m long) and interface converter for the PC. The application is designed for commissioning and service engineers as well as experienced operators.

Engineering and fitting notes

Condensate, dripping water, etc. must be prevented from entering the actuator along the carrier stem. When connecting the electricity supply, ensure that the cross-section of the power cable is adapted to the power output and the length. However, we recommend a minimum cross-section of 0.75 mm².

The actuator/ball valve is mounted by inserting and turning the bayonet ring until the limit stop without any additional adjustment. No tools are required. The coupling of the spindle of the ball valve with the carrier stem is performed automatically, either by moving the manual adjuster to an angle of rotation of 100% or connecting the voltage. For dismantling, the bayonet ring is simply opened and the actuator removed. The device is delivered ex works in the middle position.

The concept of a brushless motor, inductive travel measurement system and electronics enables the parallel operation of multiple actuators of the same SUT type.

If the actuator is currentless, the holding torque is typically reduced to 1.5 Nm.

The coding switches are accessible via an opening with a black plastic plug in the housing lid.



Beware of injury

- ▶ The housing must not be opened.



Note

- Always disconnect the device from the mains before removing the plastic plug.

Outdoor installation

In case of installation outside buildings, the devices must also be protected from the weather!

Disposal

When disposing of the product, observe the currently applicable local laws.

More information on materials can be found in the Declaration on materials and the environment for this product.

Connection diagram

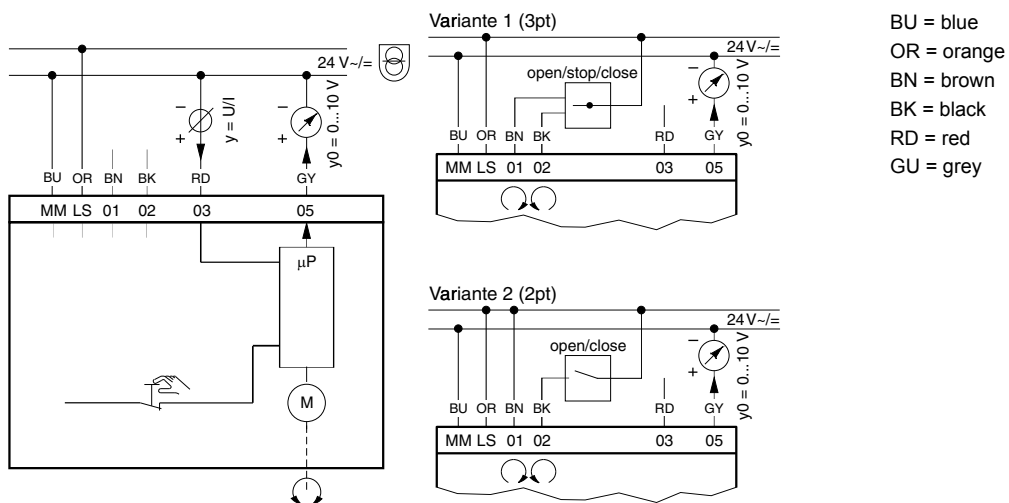

Accessories

0313529

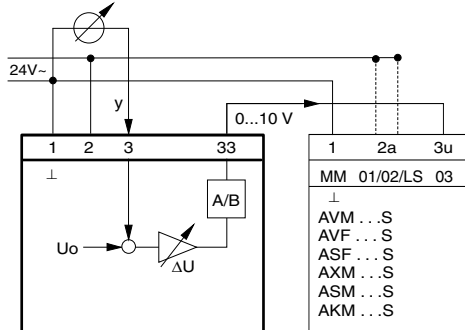

Dimension drawing

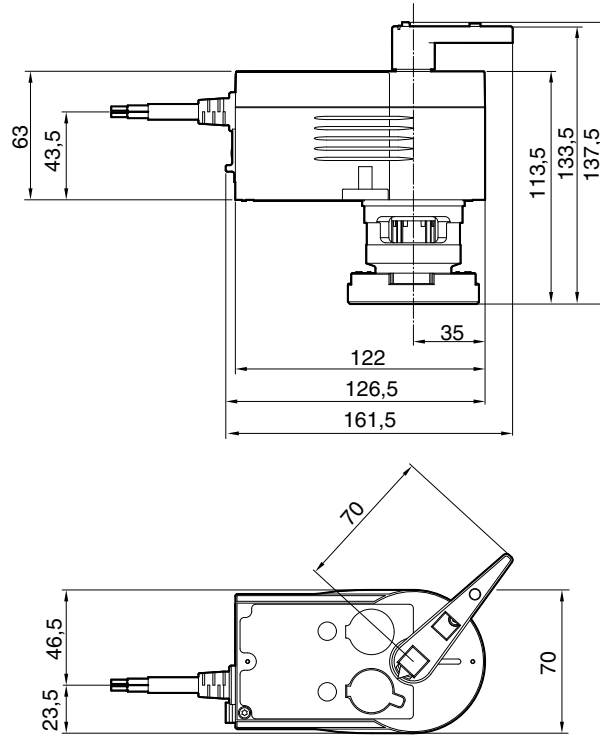

Accessories

