

CTX

Pressure sensor for general air and gas applications - stainless steel

CTX-#.#.#.###.#

Overview

- Relative pressure measurement from -1 to 200 bar
- Robust ceramic measuring cell
- Stainless steel housing
- Compact design
- Relative pressure and vacuum measurement



Technical data

Performance characteristics

Pressure type	Relative (gauged)
Compensated temperature range	-10 ... 55 °C
Long term stability	≤ 0.3 % FSR/a
Max. measuring error	± 2.5 % FSR Including zero-point and span error, non-linearity (by terminal base line), hysteresis and non-repeatability (EN 61298-2)
Max. measuring span	200 bar
Measuring range	-1 ... 200 bar
Standard error of measurement (BFSL)	± 0.5 % FSR Including non-linearity, hysteresis and non-repeatability according BFSL
Min. measuring span	1.0 bar
Rise time (10 ... 90 %)	≤ 5 ms
Temperature coefficient	≤ 0.15 % FSR/10 K , measuring span ≤ 0.25 % FSR/10 K , zero point

Process conditions

Process temperature	-40 ... 100 °C
Process pressure	Refer to section "Operating conditions"

Process connection

Connection variants	Refer to section "Dimensional drawings"
Wetted parts material, process connection	AISI 316L (1.4404)
Wetted parts material, membrane	Ceramic, 96% AL2O3
Wetted parts material, gasket	CR, optional NBR, optional EPDM, optional, O-rings are conform to 3-A Sanitary Standard 18-03 Class II, EPDM gaskets are conform to 3-A Sanitary Standard 18-03 Class I (8% milk fat max.) FKM, optional, gaskets require a minimum ambient temperature of -20 °C and a minimum medium temperature of -25 °C

Ambient conditions

Operating temperature range	-40 ... 85 °C
Storage temperature range	-40 ... 85 °C
Degree of protection (EN 60529)	IP 65
Bump (EN 60068-2-27)	100 g / 2 ms, 4000 impulses per axis and direction
Shock (EN 60068-2-27)	50 g / 11 ms, 100 g / 6 ms, 3 impulses per axis and direction
Shock and vibration tests (EN 61373:1999, 2010)	Category 1, class B
Vibration (sinusoidal) (EN 60068-2-6)	1.5 mm p-p (10 ... 55 Hz), 10 g (55 Hz ... 2 kHz), 10 cycles (2.5 h) per axis
Vibration, broad-band random (EN 60068-2-64)	0.1 g ² / Hz, > 10 gRMS (20 Hz ... 1 kHz), 30 min. per axis

Output signal

Current output	4 ... 20 mA , 2-wire
Voltage output	0 ... 10 V 0.5 ... 4.5 V DC ratiometric 1 ... 5 V
Load resistance	> 5 kΩ, with voltage output R = (U _{ver} - 11 V)/20 mA, with current output
Insulation resistance	> 100 MΩ , 250 V DC
Short circuit protection	Yes

Housing

Style	Compact transmitter
Overall size	Refer to section "Dimensional drawings"
Material	AISI 304 (1.4301)

Electrical connection

Connector	DIN EN 175301-803 A (DIN 43650 A), 4-pin M12-A, 4-pin
Cable outlet	1 m, 3-wire 2 m, 3-wire 5 m, 3-wire

CTX

Pressure sensor for general air and gas applications - stainless steel

CTX-#.#.#.###.#

Technical data

Power supply

Voltage supply range 11 ... 30 V DC , with 1 ... 5 V output signal
 11 ... 30 V DC , with 4 ... 20 mA output signal
 15 ... 30 V DC , with 0 ... 10 V output signal
 5 V DC ratiometric , with 0.5 ... 4.5 V output signal

Compliance and approvals

EMC EN 61000-6-2
 EN 61000-6-3
 EN 61326-1

Operating conditions

Measuring range (bar)	Proof pressure (bar)	Burst Pressure (bar)
-1 ... 0	0 ... 1	2
-1 ... 1,5	0 ... 2,5	4
-1 ... 3	0 ... 4	8
-1 ... 5	0 ... 6	12
-1 ... 9	0 ... 10	20
-1 ... 15	0 ... 16	32
-1 ... 24	0 ... 25	50
-1 ... 39	0 ... 40	80
	0 ... 60	120
	0 ... 100	200
	0 ... 160	320
	0 ... 200	360
		480

Dimensional drawings (mm)

Housing

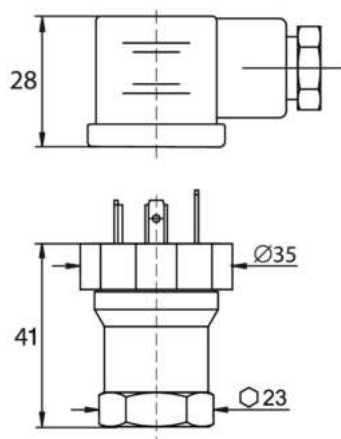

Housing with connector DIN EN 175301-803 A (DIN 43650 A), 4-pin

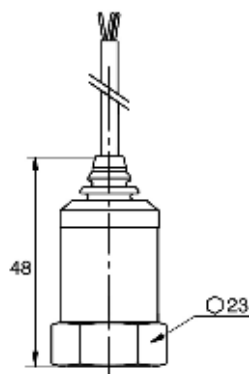

Housing with cable outlet, 3-wire

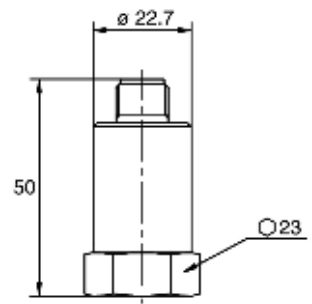

Housing with connector M12-A, 4-pin

CTX

Pressure sensor for general air and gas applications - stainless steel

CTX-#.#.#.###.#

Dimensional drawings (mm)

Process connection

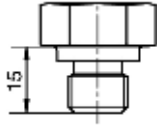

G50-06
G 1/4 A DIN 3852-E (BCID: G50)

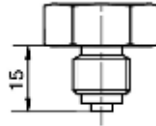

G30-02
G 1/4 B EN 837-1 (BCID: G30)

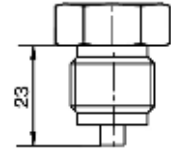

G31-3
G 1/2 B EN 837-1 (BCID: G31)

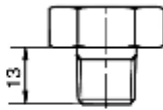

N01-5
1/4-18 NPT (BCID: N01)

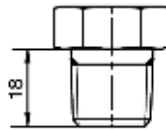

N02-6
1/2-14 NPT (BCID: N02)

CTX

Pressure sensor for general air and gas applications - stainless steel

CTX-#.#.#.###.#

Electrical connection

Output signal	Equivalent circuit	Electrical connection	Function	Pin assignment
4 ... 20 mA (2-wire)			+Vs	1
			Iout	3
			Frame Ground	Plug thread, 4
0 ... 10 V (3-wire)			+Vs	1
			Uout	2
			GND (0 V)	3
			+Vs	RD
			Iout	BK
			n.c.	WH
			+Vs	1
			Uout	2
			Frame Ground	Plug thread, 4
			+Vs	1
			Uout	3
			GND (0 V)	2
			+Vs	RD
			Uout	WH
			GND (0 V)	BK

Ordering information

Ordering key - Configuration possibilities see website

	CTX	-	#	.	#	.	#	.	###	.	#	####
Product	CTX											
Output signal												
4 ... 20 mA												3
0 ... 10 V												2
1 ... 5 V												4
0,5 ... 4,5 V ratiometric												7
Process connection												
G 1/4 A DIN 3852-E (G50)												B
G 1/4 B EN 837-1 (G30)												2
G 1/2 B EN 837-1 (G31)												3
1/4-18 NPT (N01)												5
1/2-14 NPT (N02)												6
Sealing												
NBR												3
EPDM												5
FKM												9
CR (Neoprene)												4
Measuring range												
0...1 bar (EN)												B15
0 ... 2.5 bar (EN)												B18

CTX

Pressure sensor for general air and gas applications - stainless steel

CTX-#.#.#.###.#

Ordering information

Ordering key - Configuration possibilities see website

	CTX	-	#	.	#	.	#	.	###	.	#	####
0 ... 4 bar (EN)									B19			
-1...39 bar (EN)									B1L			
0 ... 6 bar (EN)									B20			
0 ... 10 bar (EN)									B22			
0 ... 16 bar (EN)									B24			
0...25 bar (EN)									B26			
0 ... 40 bar (EN)									B27			
0 ... 60 bar (EN)									B29			
0 ... 100 bar (EN)									B31			
0 ... 160 bar (EN)									B33			
0...200 bar (EN)									B34			
-1...0 bar (EN)									B59			
-1...0,6 bar (EN)									B72			
-1 ... 1,5 bar (EN)									B74			
-1...3 bar (EN)									B76			
-1...5 bar (EN)									B77			
-1...9 bar (EN)									B79			
-1...15 bar (EN)									B81			
-1...24 bar (EN)									B82			
0...100 kPa (EN)									D15			
0...250 kPa (EN)									D18			
0...400 kPa (EN)									D19			
-100...3900 kPa (EN)									D1L			
0...600 kPa (EN)									D20			
0...1000 kPa (EN)									D22			
0...1600 kPa (EN)									D24			
0...2500 kPa (EN)									D26			
0...4000 kPa (EN)									D27			
0...6000 kPa (EN)									D29			
0...10000 kPa (EN)									D31			
0...16000 kPa (EN)									D33			
0...20000 kPa (EN)									D34			
-100...0 kPa (EN)									D59			
-100...60 kPa (EN)									D72			
-100...150 kPa (EN)									D74			
-100...300 kPa (EN)									D76			
-100...500 kPa (EN)									D77			
-100...900 kPa (EN)									D79			
-100...1500 kPa (EN)									D81			
-100...2400 kPa (EN)									D82			
0...1 kg/cm2 (EN)									F15			
0...2,5 kg/cm2 (EN)									F18			
0...4 kg/cm2 (EN)									F19			
-1...39 kg/cm2									F1L			
0...6 kg/cm2 (EN)									F20			
0...10 kg/cm2 (EN)									F22			
0...16 kg/cm2 (EN)									F24			
0...20 kg/cm2 (EN)									F25			
0...25 kg/cm2 (EN)									F26			
0...40 kg/cm2 (EN)									F27			
0...60 kg/cm2 (EN)									F29			

CTX

Pressure sensor for general air and gas applications - stainless steel

CTX-#.#.#.###.#

Ordering information

Ordering key - Configuration possibilities see website

	CTX	-	#	.	#	.	#	.	###	.	#	####
0...100 kg/cm2 (EN)									F31			
0...160 kg/cm2 (EN)									F33			
0...200 kg/cm2 (EN)									F34			
-1...0 kg/cm2 (EN)									F59			
-1...0,6 kg/cm2 (EN)									F72			
-1...1,5 kg/cm2 (EN)									F74			
-1...3 kg/cm2 (EN)									F76			
-1...5 kg/cm2 (EN)									F77			
-1...9 kg/cm2 (EN)									F79			
-1...15 kg/cm2 (EN)									F81			
-1...24 kg/cm2 (EN)									F82			
0...15 psi (ANSI)									H15			
0...30 psi (ANSI)									H17			
0...35 psi (ANSI)									H18			
0...60 psi (ANSI)									H19			
0...20 psi (ANSI)									H1C			
0...100 psi (ANSI)									H21			
0...160 psi (ANSI)									H22			
0...200 psi (ANSI)									H23			
0...250 psi (ANSI)									H24			
0...300 psi (ANSI)									H25			
0...400 psi (ANSI)									H26			
0...600 psi (ANSI)									H27			
0...1000 psi (ANSI)									H30			
0...1500 psi (ANSI)									H31			
0...2000 psi (ANSI)									H32			
Output Connection												
DIN EN 175301-803 A (DIN 43650 A), 4-pin												0
Cable outlet 1 m, 3-wire												1
Cable outlet 2 m, 3-wire												2
Cable outlet 5 m, 3-wire												5
M12-A, 4-pin												A
Signal inversion												
Signal inversion (only for 0 ... -1 bar, CTX-2 => 0 bar = 10V -1 bar = 0V CTX-3 => 0 bar = 4mA -1 bar = 20mA)												4780
not selected												&