

## Technical Information

## STF700 SmartLine Flange Mounted Level Specification 34-ST-03-103, July 2020



### Introduction

Part of the SmartLine® family of products, the STF700 is a flange mounted level transmitter suitable for monitoring, control and data acquisition featuring piezoresistive sensor technology. STF700 transmitters may be directly mounted onto a tank flange and are offered with a variety of tank connections including various flush and extended diaphragm configurations. STF700 offers high accuracy and stability over a wide range of level applications. The SmartLine family is also fully tested and compliant with Experion® PKS providing the highest level of compatibility assurance and integration capabilities. SmartLine easily meets the most demanding application needs for pressure measurement applications.

### Best in Class Features:

- Accuracies up to 0.05% of span standard & 0.04% of span optional
- Stability up to 0.02% of URL per year for 10 years
- Automatic static pressure & temperature compensation
- Rangeability up to 100:1
- Response times as fast as 100ms
- Alphanumeric display capabilities
- External zero, span, & configuration capability
- Polarity insensitive electrical connections
- Comprehensive on-board diagnostic capabilities
- Integral Dual Seal design for highest safety based on ANSI/NFPA 70-202 and ANSI/ISA 12.27.0
- World class overpressure protection
- Full compliance to SIL 2/3 requirements.
- Modular design characteristics
- Available with additional 4-year warranty



**Figure 1 – STF700 Flanged Level Transmitters feature field-proven piezoresistive sensor technology**

### Span & Range Limits:

Model	URL “inH <sub>2</sub> O (mbar)	LRL “inH <sub>2</sub> O (mbar)	Min Span “inH <sub>2</sub> O (mbar)
STF724	400 (1000)	-400 (-1000)	4.0 (10.0)
STF72F	400 (1000)	-400 (-1000)	4.0 (10.0)
Model	psi (bar)	psi (bar)	psi (bar)
STF732	100 (7.0)	-100 (-7.0)	1 (0.07)
STF73F	100 (7.0)	-100 (-7.0)	1 (0.07)

### Communications/Output Options:

- 4-20mA dc
- Honeywell Digitally Enhanced (DE)
- HART® (version 7.0)
- FOUNDATION™ Fieldbus

All transmitters are available with the above listed communications protocols.

## Description

The SmartLine family pressure transmitters are designed around a high performance piezo-resistive sensor. This one sensor actually integrates multiple sensors linking process pressure measurement with on-board static pressure (DP Models) and temperature compensation measurements. This level of performance allows the ST 700 to replace most competitive transmitters available today.

## Indication/Display Option

The ST 700 modular design accommodates a basic alphanumeric LCD display.

### Basic Alphanumeric LCD Display Features

- Modular (may be added or removed in the field)
- 0, 90, 180, & 270 degree position adjustments
- Configurable (HART only) and standard (Pa, KPa, MPa, KGcm<sup>2</sup>, Torr, ATM, inH<sub>2</sub>O, mH<sub>2</sub>O, bar, mbar, inH<sub>2</sub>O, inHG, FTH<sub>2</sub>O, mmH<sub>2</sub>O, mm HG, & psi) measurement units
- 2 Lines 16 Characters (4.13H x 1.83W mm)
- Square root output indication (√)

### Simple LCD Display Features

- Modular (may be added or removed in the field)
- Supports HART protocol variant
- 0, 90, 180, & 270 degree position adjustments
- Configurable (HART only) and standard (Pa, KPa, MPa, KGcm<sup>2</sup>, Torr, ATM, inH<sub>2</sub>O, mH<sub>2</sub>O, bar, mbar, inH<sub>2</sub>O, inHG, FTH<sub>2</sub>O, mmH<sub>2</sub>O, mm HG, & psi) measurement units.
- Supports Flow engineering units
- 2 Lines 6 digits PV (9.95H x 4.20W mm) 8 Characters
- Square root output indication (√) and Write protect Indication
- Built in Basic Device Configuration through Internal Buttons – Range/Engineering Unit/Loop Test /Loop Calibration/Zero /Span Setting

## Diagnostics

SmartLine transmitters all offer digitally accessible diagnostics which aid in providing advanced warning of possible failure events minimizing unplanned shutdowns, providing **lower overall operational costs**

## System Integration

- SmartLine communications protocols all meet the most current published standards for HART/DE/Fieldbus.
- Integration with Honeywell's Experion PKS offers the following unique advantages.
  - Tamper reporting
  - FDM Plant Area Views with Health summaries
  - All ST 700 units are Experion tested to provide the highest level of compatibility assurance

## Configuration Tools

### External Three Button Configuration Option

Suitable for all electrical and environmental requirements, SmartLine offers the ability to configure the transmitter and display via three externally accessible buttons when a display option is selected. Zero/span capabilities are also optionally available via these buttons with or without selection of the display option.

### Internal Two Button Configuration Option

The Simple display has two buttons that can be used for Basic configuration such as re ranging, PV Engineering unit setting, Zero/Span settings and Loop testing and calibration functions.

### Hand Held Configuration

SmartLine transmitters feature two-way communication and configuration capability between the operator and the transmitter. All Honeywell transmitters are designed and tested for compliance with the offered communication protocols and are designed to operate with any Standards compliant handheld configuration device.

### Personal Computer Configuration

Honeywell's SCT 3000 Configuration Toolkit provides an easy way to configure Digitally Enhanced (DE) instruments using a personal computer as the configuration interface. Field Device Manager (FDM) Software and FDM Express are also available for managing HART & Fieldbus device configurations.

## Modular Design

To help contain maintenance & inventory costs, all ST 700 transmitters are modular in design supporting the user's ability to replace meter bodies, add indicators or change electronic modules without affecting overall performance or approval body certifications. Each meter body is uniquely characterized to provide in-tolerance performance over a wide range of application variations in temperature and pressure and due to the Honeywell advanced interface, electronic modules may be swapped with any electronics module without losing in-tolerance performance characteristics.

### Modular Features

- Meter body replacement
  - Exchange/replace electronics/comms modules\*
  - Add or remove integral indicator\*
  - Add or remove lightning protection (terminal connection)\*
- \* Field replaceable in all electrical environments (including IS) except flameproof without violating agency approvals.

With no performance effects, Honeywell's unique modularity results in **lower inventory needs and lower overall operating costs**.

**Performance Specifications**

**Reference Accuracy** (conformance to +/-3 Sigma)

**Table 1**

Model	URL	LRL	Min Span	Maximum Turndown Ratio	Stability (% URL/Year for ten years)	Reference Accuracy <sup>1,2</sup> (% Span) Standard/optional
STF724	400 in H <sub>2</sub> O (1000mbar)	-400 in H <sub>2</sub> O (-1000mbar)	4 in H <sub>2</sub> O (10.0mbar)	100:1	0.02	<b>0.050 / 0.040</b>
STF72F	400 in H <sub>2</sub> O (1000mbar)	-400 in H <sub>2</sub> O (-1000mbar)	4 in H <sub>2</sub> O (10.0mbar)	100:1	0.02	
STF732	100 psi (7.0 bar)	-100 psi (-7.0 bar)	1 psi (0.07 bar)	100:1	0.03	
STF73F	100 psi (7.0 bar)	-100 psi (-7.0 bar)	1 psi (0.07 bar)	100:1	0.03	

Zero and span may be set anywhere within the listed (URL/LRL) range limits

**Accuracy, Span, Temperature and Static Pressure Effect: (Conformance to +/-3 Sigma)**

**Table 2**

		Accuracy <sup>1,2</sup> (% of Span)					Combined Zero & Span temperature Effect (% Span / 28°C (50°F))		Combined Zero & Span Static Line Pressure Effect (% Span/300psi)		
		Model	URL	Reference Turndown	A	B	C (see URL units)	D	E	F	G
Standard Accuracy	STF724	400 in H <sub>2</sub> O (1000 mbar)	16:1	0.005	0.045	25 (62.5)	0.026	0.040	0.095	0.010	
	STF72F	400 in H <sub>2</sub> O (1000 mbar)	16:1	0.005	0.045	25 (62.5)	0.050	0.020	0.025	0.005	
	STF732	100 psi (7.0 bar)	4:1	0.005	0.045	25 (1.75)	0.075	0.075	0.095	0.010	
	STF73F	100 psi (7.0 bar)	4:1	0.005	0.045	25 (1.75)	0.065	0.010	0.026	0.004	
High Accuracy Option	STF724	400 in H <sub>2</sub> O (1000 mbar)	16:1	0.005	0.035	25 (62.5)	0.026	0.040	0.095	0.010	
	STF72F	400 in H <sub>2</sub> O (1000 mbar)	16:1	0.005	0.035	25 (62.5)	0.050	0.020	0.025	0.005	
	STF732	100 psi (7.0 bar)	4:1	0.005	0.035	25 (1.75)	0.075	0.075	0.095	0.010	
	STF73F	100 psi (7.0 bar)	4:1	0.005	0.035	25 (1.75)	0.065	0.010	0.026	0.004	
<b>Turn Down Effect</b>							<b>Temp Effect</b>		<b>Static Effect</b>		
$\pm [A + B] \text{ if Span} \geq C$ $\pm \left[ A + B \left( \frac{C}{\text{Span}} \right) \right] \text{ if Span} < C$							$\pm \left[ D + E \left( \frac{\text{URL}}{\text{Span}} \right) \right]$		$\pm \left[ F + G \left( \frac{\text{URL}}{\text{Span}} \right) \right]$		

**Total Performance (% of Span):**

$$\text{Total Performance} = \pm \sqrt{(\text{Accuracy})^2 + (\text{Temp Effect})^2 + (\text{Static Line Pressure Effect})^2}$$

**Total Performance Examples (for comparison):** standard accuracy 5:1 Turndown, up to 50 °F shift & up to 300 psi Static Pressure

**STF724 @ 80" H<sub>2</sub>O:** 0.273% of span

**STF732 @ 20 psi:** 0.477 % of span

**STF72F @ 80" H<sub>2</sub>O:** 0.166% of span

**STF73F@ 20 psi:** 0.138% of span

**Typical Calibration Frequency:**

Calibration verification is recommended every two (2) years

**Notes:**

1. Terminal Based Accuracy – Includes effects of linearity, hysteresis and repeatability. Analog output adds 0.005% of span
  2. For zero based spans and reference conditions of 25°C, 0 psig static pressure, 10 to 55% RH.
-

## Operating Conditions – All Models

Parameter	Reference Condition		Rated Condition		Operative Limits		Transportation and Storage	
	°C	°F	°C	°F	°C	°F	°C	°F
<b>Ambient Temperature</b>	25±1	77±2	-40 to 85	-40 to 185	-40 to 85	-40 to 185	-55 to 120	-67 to 248
<b>Meter Body Temperature</b>	25±1	77±2	-40 to 110 <sup>1</sup>	-40 to 230 <sup>1</sup>	-40 to 125	-40 to 257	-55 to 120	-67 to 248
<b>Process Interface Temp.</b> STF724, STF732 only	25±1	77±2	-40 to 110 <sup>1</sup>	-40 to 230 <sup>1</sup>	-40 to 175 <sup>2</sup>	-40 to 350 <sup>2</sup>	-55 to 125	-67 to 257
<b>Humidity</b> %RH	10 to 55		0 to 100		0 to 100		0 to 100	
<b>Minimum Pressure</b> mmHg absolute inH <sub>2</sub> O absolute	atmospheric atmospheric		25 13		2 (short term <sup>3</sup> ) 1 (short term <sup>3</sup> )			
<b>Supply Voltage</b>	10.8 to 42.4 Vdc at terminals							
<b>Load Resistance</b>	0 to 1,440 ohms (as shown in <a href="#">Figure 2</a> )							

<sup>1</sup> Silicone 704 minimum temperature rating is 0°C (32°F). NEOBEE® M-20 minimum temperature rating is -15°C (5°F)

NEOBEE® is a registered trademark of Stepan Company

<sup>2</sup> For CTFE fill fluid, the maximum temperature rating is 150°C (300°F)

<sup>3</sup> Short term equals 2 hours at 70°C (158 °F)

### Maximum Allowable Working Pressure (MAWP) <sup>5, 6</sup>

(ST 800 products are rated to Maximum Allowable Working Pressure. MAWP depends on Approval Agency and transmitter materials of construction.)

STF 724 & STF 732	Flange Material	Ambient Temperature -29 to 38°C [-20 to 100°F]	Max Meterbody Temperature 125°C [257°F]	Process Interface Temperature 175°C [350°F]
ANSI Class 150 <b>psi [bar]</b>	Carbon Steel	285 [19.6]	245 [16.9]	215 [14.8]
	304 S.S.	275 [19.0]	218 [15.0]	198 [13.7]
	316 S.S.	275 [19.0]	225 [15.5]	205 [14.1]
ANSI Class 300 <b>psi [bar]</b>	Carbon Steel	740 [51.0]	668 [46.0]	645 [44.5]
	304 S.S.	720 [49.6]	570 [39.3]	518 [35.7]
	316 S.S.	720 [49.6]	590 [40.7]	538 [37.1]
DN PN40 <b>psi [bar]</b>	Carbon Steel	580 [40.0] <sup>4</sup>	574 [39.6]	559 [38.5]
	304 S.S.	534 [36.8] <sup>4</sup>	419 [28.9]	385 [26.5]
	316 S.S.	534 [36.8] <sup>4</sup>	434 [29.9]	399 [27.5]
<b>STF72F&amp; STF73F</b> ANSI Class 150 psi [bar]	316L Stainless Steel	230 [15.9]	185 [12.8]	No rating at this temp

<sup>4</sup> Ambient Temperature for DN PN40 is -10 to 50°C [14 to 122 F]

<sup>5</sup> MAWP applies for temperature range -40 to 125°C. However, Static Pressure Limit is de-rated to 3,000 psi from -26°C to -40°C.

Use of graphite o-rings de-rates transmitter to 3,625 psi. Use of adaptor with graphite o-rings de-rates transmitter to 3,000 psi.

<sup>6</sup> Consult factory for MAWP of ST 800 transmitters with CSA approval.

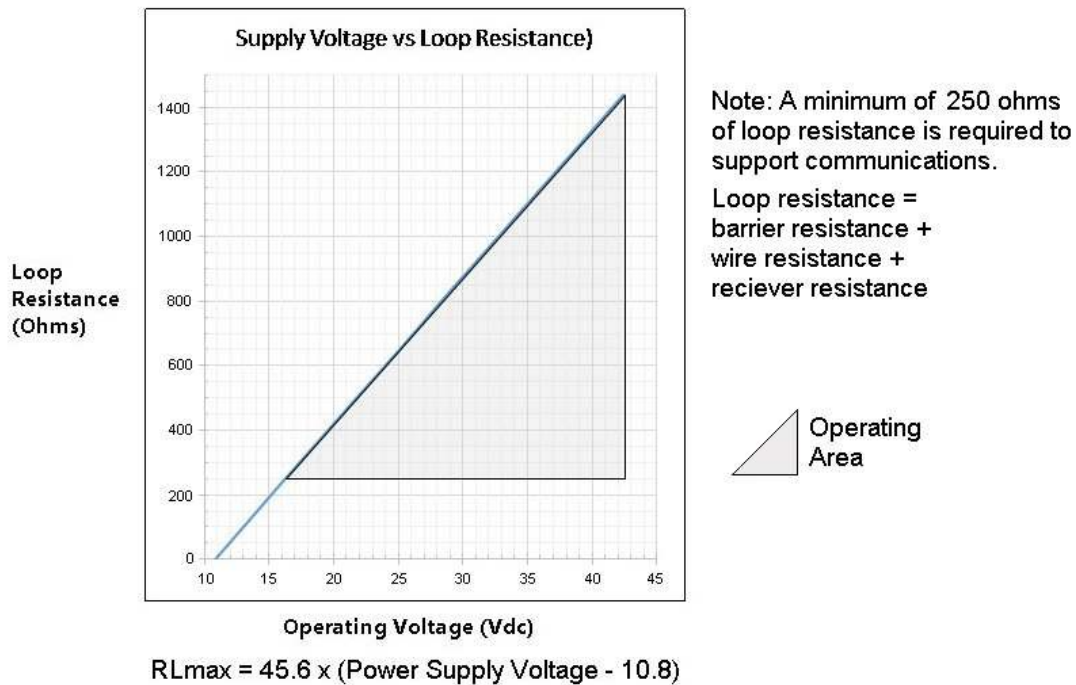

Figure 2 - Supply voltage and loop resistance chart & calculations

### Performance Under Rated Conditions – All Models

Parameter	Description												
<b>Analog Output</b> <b>Digital Communications:</b>	Two-wire, 4 to 20 mA (HART & DE Transmitters only) Honeywell DE, HART 7 protocol or FOUNDATION Fieldbus ITK 6.0.1 compliant All transmitters, irrespective of protocol have polarity insensitive connection.												
<b>HART &amp; DE Output Failure Modes</b> (NAMUR for DE Units requires selecting display and configuration buttons or factory configuration)	<table border="0"> <thead> <tr> <th></th> <th>Honeywell Standard:</th> <th>NAMUR NE 43</th> </tr> </thead> <tbody> <tr> <td><b>Compliance:</b></td> <td></td> <td></td> </tr> <tr> <td><b>Normal Limits:</b></td> <td>3.8 – 20.8 mA</td> <td>3.8 – 20.5 mA</td> </tr> <tr> <td><b>Failure Mode:</b></td> <td>≤ 3.6 mA and ≥ 21.0 mA</td> <td>≤ 3.6 mA and ≥ 21.0 mA</td> </tr> </tbody> </table>		Honeywell Standard:	NAMUR NE 43	<b>Compliance:</b>			<b>Normal Limits:</b>	3.8 – 20.8 mA	3.8 – 20.5 mA	<b>Failure Mode:</b>	≤ 3.6 mA and ≥ 21.0 mA	≤ 3.6 mA and ≥ 21.0 mA
	Honeywell Standard:	NAMUR NE 43											
<b>Compliance:</b>													
<b>Normal Limits:</b>	3.8 – 20.8 mA	3.8 – 20.5 mA											
<b>Failure Mode:</b>	≤ 3.6 mA and ≥ 21.0 mA	≤ 3.6 mA and ≥ 21.0 mA											
<b>Supply Voltage Effect</b>	0.005% span per volt.												
<b>Transmitter Turn on Time (includes power up &amp; test algorithms)</b>	HART or DE: 2.5 sec.                      Foundation Fieldbus: Host dependant												
<b>Response Time (delay + time constant)</b>	<table border="0"> <thead> <tr> <th><u>DE/HART Analog Output</u></th> <th><u>FOUNDATION Fieldbus</u></th> </tr> </thead> <tbody> <tr> <td>90mS</td> <td>150mS (Host Dependant)</td> </tr> </tbody> </table>	<u>DE/HART Analog Output</u>	<u>FOUNDATION Fieldbus</u>	90mS	150mS (Host Dependant)								
<u>DE/HART Analog Output</u>	<u>FOUNDATION Fieldbus</u>												
90mS	150mS (Host Dependant)												
<b>Damping Time Constant</b>	<b>HART:</b> Adjustable from 0 to 32 seconds in 0.1 increments. <b>Default:</b> 0.50 seconds <b>DE:</b> Discrete values 0, .16, .32, .48, 1, 2, 4, 8, 16, 32 seconds. <b>Default:</b> 0.48 seconds												
<b>Vibration Effect</b>	Less than +/- 0.1% of URL w/o damping Per IEC60770-1 field or pipeline, high vibration level (10-2000Hz: 0.21 displacement/3g max acceleration)												
<b>Electromagnetic Compatibility</b>	IEC 61326-3-1												
<b>Lightning Protection Option</b>	<b>Leakage Current:</b> 10uA max @ 42.4VDC 93C <b>Impulse rating:</b> 8/20uS      5000A (>10 strikes)      10000A (1 strike min.) 10/1000uS      200A (> 300 strikes)												

## Materials Specifications (see model selection guide for availability/restrictions with various models)

Parameter	Description
<b>Barrier Diaphragms Material</b>	316L SS, Hastelloy® C-276 <sup>2</sup> , Monel® 400 <sup>**3</sup>
<b>Process Head Material</b>	316 SS <sup>4</sup> , Carbon Steel (Zinc-plated) <sup>5</sup> , Hastelloy C-276 <sup>*6</sup> , Monel 400 <sup>**7</sup>
<b>Vent/Drain Valves &amp; Plugs<sup>1</sup></b>	316 SS <sup>4</sup> , Hastelloy C-276 <sup>2</sup> , Monel 400 <sup>7</sup>
<b>Gasket Ring Material (Wetted)</b>	316/316L SS, Hastelloy® C-276 <sup>*2</sup> , Monel®400 <sup>**3</sup>
<b>Extension Tube Material</b>	316 SS <sup>4</sup>
<b>Head Gaskets</b>	Glass-filled PTFE standard. Viton® and graphite are optional.
<b>Meter Body Bolting</b>	Carbon Steel (Zinc plated) standard. Options include 316 SS, NACE A286 SS bolts, Monel K500, Super Duplex and B7M.
<b>Optional Adapter Flange and Bolts</b>	Adapter Flange materials include 316 SS <sup>4</sup> , Hastelloy C-276 <sup>6</sup> and Monel 400 <sup>7</sup> . Bolt material for flanges is dependent on process head bolts material chosen. Standard adaptor seal material is glass-filled PTFE. Viton and graphite are optional.
<b>Mounting Flange</b> STF724, STF732 STF72F, STF73F	<b>Flush or Extended Diaphragm:</b> Zinc Chromate plated Carbon Steel <sup>5</sup> , 304 SS, or 316 SS <sup>4</sup> . 316L SS ( <i>NOTE: Mounting Flange is process wetted.</i> )
<b>Fill Fluid</b>	Silicone 200, CTFE, NEOBEE M-20 or Silicone 704
<b>Electronic Housing</b>	Pure Polyester Powder Coated Low Copper (<0.4%)-Aluminum. Meets NEMA 4X, IP66, & P67. All stainless steel housing is optional.
<b>Mounting</b>	See <a href="#">Figure 3</a> for typical flange mounting arrangement.
<b>Process Connections</b>  All Models STF724, STF732  STF72F, STF73F	<b>Process Head:</b> 1/4-inch NPT; 1/2-inch NPT with adapter and DIN, standard options. <b>Flange:</b> 2, 3 or 4-inch Class 150 or 300 ANSI; DN50-PN40, DN80-PN40 or DN100-PN40 DIN flange. <b>Extended Diaphragm:</b> 2, 4, or 6 inches (50, 101, 152 mm) long.  2 or 3-inch, Class 150 ANSI flange.
<b>Wiring</b>	Accepts up to 16 AWG (1.5 mm diameter).
<b>Dimensions</b>	See <a href="#">Figure 4</a> , <a href="#">Figure 5</a> & <a href="#">Figure 6</a>
<b>Net Weight</b>	STF72F, STF73F: 14-19 pounds (6.4 - 8.7Kg) with Aluminum Housing STF724, STF732: 18-32 pounds (8.2 - 14.5Kg) with Aluminum Housing

<sup>1</sup> Vent/Drains are sealed with Teflon®

<sup>2</sup> Hastelloy C-276 or UNS N10276

<sup>3</sup> Monel 400 or UNS N04400

<sup>4</sup> Supplied as 316 SS or as Grade CF8M, the casting equivalent of 316 SS.

<sup>5</sup> Carbon Steel heads are zinc-plated and not recommended for water service due to hydrogen migration. For that service, use 316 stainless steel wetted Process Heads.

<sup>6</sup> Hastelloy C-276 or UNS N10276. Supplied as indicated or as Grade CW12MW, the casting equivalent of Hastelloy C-276

<sup>7</sup> Monel 400 or UNS N04400. Supplied as indicated or as Grade M30C, the casting equivalent of Monel 400

\* Flush design only.

\*\*Flush or pseudo flange design.



## Communications Protocols & Diagnostics

### HART Protocol

**Version:**

HART 7

**Power Supply**

Voltage: 10.8 to 42.4Vdc at terminals

Load: Maximum 1440 ohms See [Figure 2](#).

Minimum Load: 0 ohms. (For handheld communications a minimum load of 250 ohms is required)

### Foundation Fieldbus (FF)

**Power Supply Requirements**

Voltage: 9.0 to 32.0Vdc at terminals

Steady State Current: 17.6mAdc

Software Download Current: 27.4mAdc

**Available Function Blocks**

Block Type	Qty	Execution Time
Resource	1	n/a
Transducer	1	n/a
Diagnostic	1	n/a
Analog Input	1*	30 ms
PID w/Autotune	1	45 ms
Integrator	1	30 ms
Signal Char (SC)	1	30 ms
LCD Display	1	n/a
Flow Block	1	30 ms
Input Selector	1	30 ms
Arithmetic	1	30 ms

\* AI block may have two (2) additional instantiations.

All available function blocks adhere to FOUNDATION Fieldbus standards. PID blocks support ideal & robust PID algorithms with full implementation of Auto-tuning.

**Link Active Scheduler**

Transmitters can perform as a backup Link Active Scheduler and take over when the host is disconnected. Acting as a LAS, the device ensures scheduled data transfers typically used for the regular, cyclic transfer of control loop data between devices on the Fieldbus.

**Number of Devices/Segment**

Entity IS model: 6 devices/segment

**Schedule Entries**

18 maximum schedule entries

**Number of VCR's:** 24 max

**Compliance Testing:** Tested according to ITK 6.0.1

**Software Download**

Utilizes Class-3 of the Common Software Download procedure as per FF-883 which allows the field devices of any manufacturer to receive software upgrades from any host.

**Honeywell Digitally Enhanced (DE)**

DE is a Honeywell proprietary protocol which provides digital communications between Honeywell DE enabled field devices and Hosts.

**Power Supply**

Voltage: 10.8 to 42.4Vdc at terminals

Load: Maximum 1440 ohms See [Figure 2](#).

**Standard Diagnostics**

ST 700 top level diagnostics are reported as either critical or non-critical and readable via the DD/DTM tools or integral display as shown below.

**Critical Diagnostics**

HART DD/DTM Tools	Basic Display	Simple Display
Electronic Module DAC Failure	Electronics module fault	Fault Comm EI
Meter Body NVM Corrupt	Meter Body fault	Fault Mtrbody
Config. Data Corrupt	Electronics module fault	Fault Comm EI
Electronic Module Diag Failure	Electronics module fault	Fault Comm EI
Meter Body Critical Failure	Meter Body fault	Fault Mtrbody
Sensor Comms Timeout	Meter Body Comm fault	Fault Mbd Com

**Non-Critical Diagnostics**

HART DD/DTM Tools
Display Failure
Electronic Module Comm Failure
Meter Body Excess Correct
Sensor Over Temperature
Fixed Current Mode
PV Out of Range
No Factory Calibration
No DAC Compensation
LRV Set Error – Zero Config. Button
URV Set Error – Zero Config. Button
AO Out of Range
Loop Current Noise
Meter Body Unreliable Comm
Tamper Alarm,
No DAC Calibration
Sensor Supply Voltage Low

Refer to ST 700 manuals for additional level diagnostic information.



**Hazardous Areal Certifications:**

MSG CODE	AGENCY	TYPE OF PROTECTION	COMM. OPTION	ELECTRICAL PARAMETERS	AMBIENT TEMP (Ta)
A	FM Approvals™ USA	<b>Explosionproof:</b> Class I, Division 1, Groups A, B, C, D; Dust Ignition Proof: Class II, III, Division 1, Groups E, F, G; T6..T5 Class I, Zone 0/1, AEx db IIC T6..T5 Ga/Gb Class II, Zone 21, AEx tb IIIC T95° Db	All	Note 1	T5: -50 °C to 85°C T6: -50 °C to 65°C
		<b>Intrinsically Safe:</b> Class I, II, III, Division 1, Groups A, B, C, D, E, F, G: T4 Class I, Zone 0, AEx ia IIC T4 Ga FISCO Field Device (Only for FF Option) Ex ia IIC T4 Ga; Ex ic IIC T4 Gc	4-20 mA / DE/ HART	Note 2a	-50 °C to 70°C
		<b>Nonincendive:</b> Class I, Division 2, Groups A, B, C, D locations, T4 Class I, Zone 2, AEx nA IIC T4 Gc	Foundation Fieldbus	Note 2b	-50 °C to 70°C
		<b>Nonincendive:</b> Class I, Division 2, Groups A, B, C, D locations, T4 Class I, Zone 2, AEx nA IIC T4 Gc	4-20 mA / DE/ HART/ Foundation Fieldbus	Note 1	-50 °C to 85°C
		<b>Enclosure:</b> Type 4X/ IP66/ IP67	All	All	-
		<b>STANDARDS:</b> FM Class 3600:2011; FM Class 3610: 2010; FM Class 3611: 2004; FM Class 3615: 2006; FM Class 3616: 2011; FM Class 3810: 2005; ANSI/ISA 60079-0: 2013; ANSI/UL 60079-1: 2015; ANSI/UL 60079-11: 2014; ANSI/ISA 60079-15: 2012; ANSI/UL 60079-26: 2017; ANSI/UL 60079-31: 2015; ANSI/NEMA 250: 2003; ANSI/ IEC 60529: 2004			
B	Canadian Standards Association (CSA) USA and Canada	<b>Explosion Proof:</b> Class I, Division 1, Groups A, B, C, D; Class II, Division 1, Groups E, F, G; Class III, Division 1, T6..T5 Class I Zone 1 AEx db IIC T6..T5 Ga/Gb Ex db IIC T6..T5 Ga/Gb Zone 22 AEx tb IIIC T95° Db Ex tb IIIC T95° Db	All	Note 1	T5: -50°C TO 85°C T6: -50°C TO 65°C
		<b>Intrinsically Safe:</b> Class I, II, III, Division 1, Groups A, B, C, D; Class II, Division 1, Groups E, F, G; Class III, Division 1, T4 Class I Zone 0, AEx ia IIC T4 Ga Class I Zone 2, AEx ic IIC T4 Gc Ex ia IIC T4 Ga Ex ic IIC T4 Gc FISCO Field Device (Only for FF Option) Ex ia IIC T4 Ga; Ex ic IIC T4 Gc	4-20 mA / DE/ HART	Note 2	-50°C TO 70°C
		<b>Nonincendive:</b> Class I, Division 2, Groups A, B, C, D; Class II, Division 2, Groups F, G; Class III, Division 2, T4 Class I Zone 2 AEx nA IIC T4 Gc Ex nA IIC T4 Gc	Foundation Fieldbus	Note 2	-50°C TO 70°C
		<b>Nonincendive:</b> Class I, Division 2, Groups A, B, C, D; Class II, Division 2, Groups F, G; Class III, Division 2, T4 Class I Zone 2 AEx nA IIC T4 Gc Ex nA IIC T4 Gc	4-20 mA / DE/ HART/ Foundation Fieldbus	Note 1	-50°C to 85°C
		<b>Enclosure:</b> Type 4X/ IP66/ IP67	All	All	-

MSG CODE	AGENCY	TYPE OF PROTECTION	COMM. OPTION	ELECTRICAL PARAMETERS	AMBIENT TEMP (Ta)
		<b>STANDARDS:</b> CSA C22.2 No. 0-10; CSA C22.2 No. 94-M91; CSA C22.2 No. 25-1966; CSA C22.2 No. 30-M1986; CSA C22.2 No. 142-M1987; CSA C22.2 No. 157-92; CSA C22.2 No. 213-M1987; CSA-C22.2 No. 60529:05; CSA-C22.2 No. 60079-0:11; CSA-C22.2 No. 60079-1:11; CSA-C22.2 No. 60079-11:11; CSA-C22.2 No. 60079-15:12; CSA-C22.2 No. 60079-31:12; ISA 12.12.01-2010; ISA 60079-0: 2009; ISA 60079-11: 2011; ISA 60079-15: 2009; ISA 60079-26: 2008; ISA-60079-27:2007 (12.02.04)-2006 (R2011); UL 913 Ed. 6; UL 916:1998; ANSI/ISA-12.27.01-2011			
C	ATEX	<b>Flameproof: SIRA 12ATEX2233X</b> II 1/2 G Ex db IIC T6..T5 Ga/Gb II 2 D Ex tb IIIC T95°C...T120°C Db	All	Note 1	T5: -50°C TO 85°C T6: -50°C TO 65°C
		<b>Intrinsically Safe: SIRA 12ATEX2233X</b> II 1 G Ex ia IIC T4 Ga FISCO Field Device (Only for FF Option) II 1 G Ex ia IIC T4 Ga	4-20 mA / DE/ HART	Note 2	-50°C TO 70°C
			Foundation Fieldbus	Note 2	-50°C TO 70°C
		<b>Zone 2, Increase Safety: SIRA 12ATEX4234X</b> II 3 G Ex ec IIC T4 Gc	4-20 mA / DE/ HART/	Note 1	-50°C TO 85°C
		<b>Zone 2, Intrinsically Safe: SIRA 12ATEX4234X</b> II 3 G Ex ic IIC T4 Gc FISCO Field Device (Only for FF Option) II 3 G Ex ic IIC T4 Gc	4-20 mA / DE/ HART/ Foundation Fieldbus	Note 2	-50°C TO 85°C
		<b>Enclosure:</b> IP66/ IP67	All	All	-
		<b>STANDARDS:</b> EN 60079-0: 2012/A11: 2013; EN 60079-1: 2014; EN 60079-7: 2015; EN 60079-11: 2012; EN 60079-26: 2015; EN 60079-31: 2009			
D	IECEX World	<b>Flameproof: IECEx SIR 12.0100X</b> Ex db IIC T6..T5 Ga/Gb Ex tb IIIC T95°C...T120°C Db	All	Note 1	T5: -50°C TO 85°C T6: -50°C TO 65°C
		<b>Intrinsically Safe: IECEx SIR 12.0100X</b> Ex ia IIC T4 Ga FISCO Field Device (Only for FF Option) Ex ia IIC T4 Ga; Ex ic IIC T4 Gc	4-20 mA / DE/ HART	Note 2	-50°C TO 70°C
			Foundation Fieldbus	Note 2	-50°C TO 70°C
		<b>Zone 2, Increase Safety: IECEx SIR 12.0100X</b> Ex ec IIC T4 Gc	4-20 mA / DE/ HART/ Foundation Fieldbus	Note 1	-50°C TO 85°C
		<b>Zone 2, Intrinsically Safe: IECEx SIR 12.0100X</b> Ex ic IIC T4 Gc FISCO Field Device (Only for FF Option) Ex ic IIC T4 Gc	4-20 mA / DE/ HART/ Foundation Fieldbus	Note 2	-50°C TO 85°C
		<b>Enclosure:</b> IP66/ IP67	All	All	-
		<b>STANDARDS:</b> IEC 60079-0: 2011; IEC 60079-1: 2014; IEC 60079-7: 2017; IEC 60079-11: 2011; IEC 60079-26: 2014; IEC 60079-31: 2013			

E	SAEx South Africa	<b>Flameproof :</b> Ex d IIC T6...T5 Ga/Gb Ex tb IIIC T95°C...T120°C Db	All	Note 1	T5: -50°C TO 85°C T6: -50°C TO 65°C
		<b>Intrinsically Safe:</b> Ex ia IIC Ga T4 FISCO Field Device (Only for FF Option) Ex ia IIC T4 Ga; Ex ic IIC T4 Gc	4-20 mA / DE/ HART	Note 2	-50°C TO 70°C
			Foundation Fieldbus	Note 2	-50°C TO 70°C
		<b>Zone 2, Increase Safety:</b> II 3 G Ex ec IIC T4 Gc	4-20 mA / DE/ HART/ Foundation Fieldbus	Note 1	-50°C TO 85°C
		<b>Zone 2, Intrinsically Safe:</b> Ex ic IIC T4 Gc FISCO Field Device (Only for FF Option) Ex ic IIC T4 Gc	4-20 mA / DE/ HART/ Foundation Fieldbus	Note 2	-50°C TO 85°C
<b>Enclosure:</b> IP66/ IP67	All	All	-		
F	INMETRO Brazil	<b>Flameproof:</b> Ex db IIC T6..T5 Ga/Gb Ex tb IIIC T95°C...T120°C Db	All	Note 1	T5: -50°C TO 85°C T6: -50°C TO 65°C
		<b>Intrinsically Safe:</b> Ex ia IIC T4 Ga  FISCO Field Device (Only for FF Option) Ex ia IIC T4 Ga; Ex ic IIC T4 Gc	4-20 mA / DE/ HART	Note 2a	-50°C TO 70°C
			Foundation Fieldbus	Note 2b	-50°C TO 70°C
		<b>Zone 2, Increase Safety:</b> II 3 G Ex ec IIC T4 Gc	4-20 mA / DE/ HART/ Foundation Fieldbus	Note 1	-50°C TO 85°C
		<b>Zone 2, Intrinsically Safe:</b> Ex ic IIC T4 Gc FISCO Field Device (Only for FF Option) Ex ic IIC T4 Gc	4-20 mA / DE/ HART/ Foundation Fieldbus	Note 2	-50°C TO 85°C
		<b>Enclosure :</b> IP 66/67	All	All	-
G	NEPSI CHINA	<b>Flameproof:</b> Ex db IIC T6..T5 Ga/Gb Ex tb IIIC T 95°C Db	All	Note 1	T5: -50°C TO 85°C T6: -50°C TO 65°C
		<b>Intrinsically Safe:</b> Ex ia IIC T4 Ga FISCO Field Device (Only for FF Option) Ex ia IIC T4 Ga; Ex ic IIC T4 Gc	4-20 mA / DE/ HART	Note 2	-50°C TO 70°C
			Foundation Fieldbus	Note 2	-50°C TO 70°C
		<b>Zone 2, Increase Safety:</b> II 3 G Ex ec IIC T4 Gc	4-20 mA / DE/ HART/ Foundation Fieldbus	Note 1	-50°C TO 85°C
		<b>Zone 2, Intrinsically Safe:</b> Ex ic IIC T4 Gc FISCO Field Device (Only for FF Option) Ex ic IIC T4 Gc	4-20 mA / DE/ HART/ Foundation Fieldbus	Note 2	-50°C TO 85°C
		<b>Enclosure :</b> IP 66/67	All	All	-

H	KOSHA Korea	<b>Flameproof :</b> Ex d IIC T4, T5, T6 Ex tD A21 IP66/IP67 T95°C...T120 °C	All	Note 1	T4: -50°C TO 85°C T5: -50°C TO 85°C T6: -50°C TO 65°C
		<b>Intrinsically Safe:</b> Ex ia IIC T4	4-20 mA / DE/ HART	Note 2	Ta= -50 °C to 70°C
			Foundation Fieldbus	Note 2	Ta= -50 °C to 70°C
<b>Enclosure:</b> IP66/ IP67		All	All	-	
I	EAC Russia, Belarus and Kazakhstan	<b>Flameproof:</b> Ga/Gb Ex d IIC T6..T5 Ex tb IIIC Db T 85°C	All	Note 1	T5: -50°C TO 85°C T6: -50°C TO 65°C
		<b>Intrinsically Safe:</b> Ga Ex ia IIC T4 X FISCO Field Device (Only for FF Option) Ga Ex ia IIC T4 X	4-20 mA / DE/ HART	Note 2	-50°C TO 70°C
			Foundation Fieldbus	Note 2	-50°C TO 70°C
		<b>Zone 2, Non Sparking:</b> 2 Ex nA IIC T4 Gc X	4-20 mA / DE/ HART/ Foundation Fieldbus	Note 1	-50°C TO 85°C
		<b>Zone 2, Intrinsically Safe:</b> Ga Ex ic IIC T4 X FISCO Field Device (Only for FF Option) 2 Ex ic IIC T4 Gc X	4-20 mA / DE/ HART/ Foundation Fieldbus	Note 2	-50°C TO 85°C
<b>Enclosure :</b> IP 66/67		All	All		
J	CCoE INDIA	<b>Flameproof:</b> Ex d IIC T6..T5 Ga/Gb	All	Note 1	T5: -50°C TO 85°C T6: -50°C TO 65°C
		<b>Intrinsically Safe:</b> Ex ia IIC T4 Ga FISCO Field Device (Only for FF Option) Ex ia IIC T4 Ga; Ex ic IIC T4 Gc	4-20 mA / DE/ HART	Note 2	-50°C TO 70°C
			Foundation Fieldbus	Note 2	-50°C TO 70°C
		<b>Non Sparking</b> Ex nA IIC T4 Gc	4-20 mA / DE/ HART/ Foundation Fieldbus	Note 1	-50°C TO 85°C
<b>Enclosure:</b> IP66/ IP67		All	All	-	
K	UATR UKRAINE	<b>Flameproof:</b> II 1/2 G Ex db IIC T6..T5 Ga/Gb II 2 D Ex tb IIIC T95°C...T120°C Db	All	Note 1	T5: -50°C TO 85°C T6: -50°C TO 65°C
		<b>Intrinsically Safe:</b> II 1 G Ex ia IIC T4 Ga FISCO Field Device (Only for FF Option) II 1 G Ex ia IIC T4 Ga	4-20 mA / DE/ HART	Note 2	-50°C TO 70°C
			Foundation Fieldbus	Note 2	-50°C TO 70°C
<b>Enclosure:</b> IP66/ IP67		All	All	-	

**Notes:**

1. Operating Parameters:

Voltage= 11 to 42 V DC      Current= 4-20 mA Normal  
 = 10 to 30 V (FF)              = 30 mA (FF)

2. Intrinsically Safe Entity Parameters

a. Analog/ DE/ HART Entity Values:

Vmax= Ui = 30V      Imax= li= 105mA      Ci = 4.2nF      Li =984 uH      Pi =0.9W

Transmitter with Terminal Block Revision E or Later

Vmax= Ui = 30V      Imax= li= 225mA      Ci = 4.2nF      Li = 0      Pi =0.9W

Note : Transmitter with Terminal Block Revision E or later

The revision is on the label that is on the module. There will be two lines of text on the label:

- First is the Module Part #: 50049839-001 or 50049839-002
- Second line has the supplier information, along with the REVISION:  
 XXXXXX-EXXXX, THE "X" is production related, THE POSITION of the "E" IS THE REVISION.

b. Foundation Fieldbus- Entity Values

Vmax= Ui = 30V      Imax= li= 180mA      Ci = 0nF      Li = 984 uH      Pi =1W

Transmitter with Terminal Block Revision F or Later

Vmax= Ui = 30V      Imax= li= 225mA      Ci =0nF      Li = 0      Pi =1 W

FISCO Field Device

Imax= li= 380 mA      Ci = 0nF      Li = 0      Pi =5.32 W

Vmax= Ui = 17.5V

Note : Transmitter with Terminal Block Revision F or later

The revision is on the label that is on the module. There will be two lines of text on the label:

- First is the Module Part #: 50049839-003 or 50049839-004
- Second line has the supplier information, along with the REVISION:  
 XXXXXX-EXXXX, THE "X" is production related, THE POSITION of the "E" IS THE REVISION.

**Approval Certifications: (Continued)**

<b>Marine Certificates</b>	This certificate defines the certifications covered for the ST 800 Pressure Transmitter family of products, including the SMV 800 Smart Multivariable Transmitter. It represents the compilation of the five certificates Honeywell currently has covering the certification of these products into marine applications. For SmartLine Pressure Transmitter and SMV800 Smart Multivariable Transmitter
	<b>American Bureau of Shipping (ABS)</b> - 2009 Steel Vessel Rules 1-1-4/3.7, 4-6-2/5.15, 4-8-3/13 & 13.5, 4-8-4/27.5.1, 4-9-7/13. Certificate number: 04-HS417416-PDA
	<b>Bureau Veritas (BV)</b> - Product Code: 389:1H. Certificate number: 12660/B0 BV
	<b>Det Norske Veritas (DNV)</b> - Location Classes: Temperature D, Humidity B, Vibration A, EMC B, Enclosure C. For salt spray exposure; enclosure of 316 SST or 2-part epoxy protection with 316 SST bolts to be applied. Certificate number: A-11476
	<b>Korean Register of Shipping (KR)</b> - Certificate number: LOX17743-AE001
	<b>Lloyd's Register (LR)</b> - Certificate number: 02/60001(E1) & (E2)
<b>SIL 2/3 Certification</b>	IEC 61508 SIL 2 for non-redundant use and SIL 3 for redundant use according to EXIDA and TÜV Nord Sys Tec GmbH & Co. KG under the following standards: IEC61508-1: 2010; IEC 61508-2: 2010; IEC61508-3: 2010.

**Other Certification Options**

**Materials**

- NACE MRO175, MRO103, ISO15156

**Dimensional Drawings**

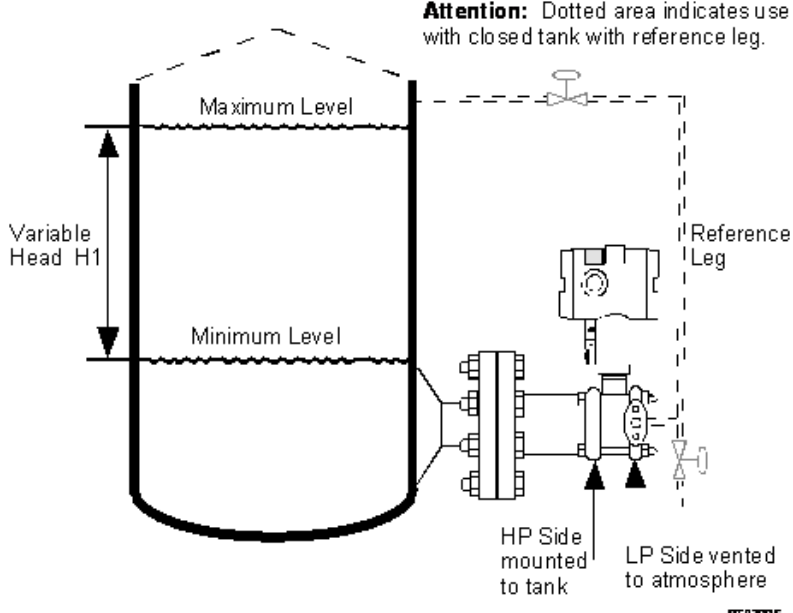

**Figure 3 – Typical mounting for flange mounted level transmitter**

## Dimensional Drawings (con't)

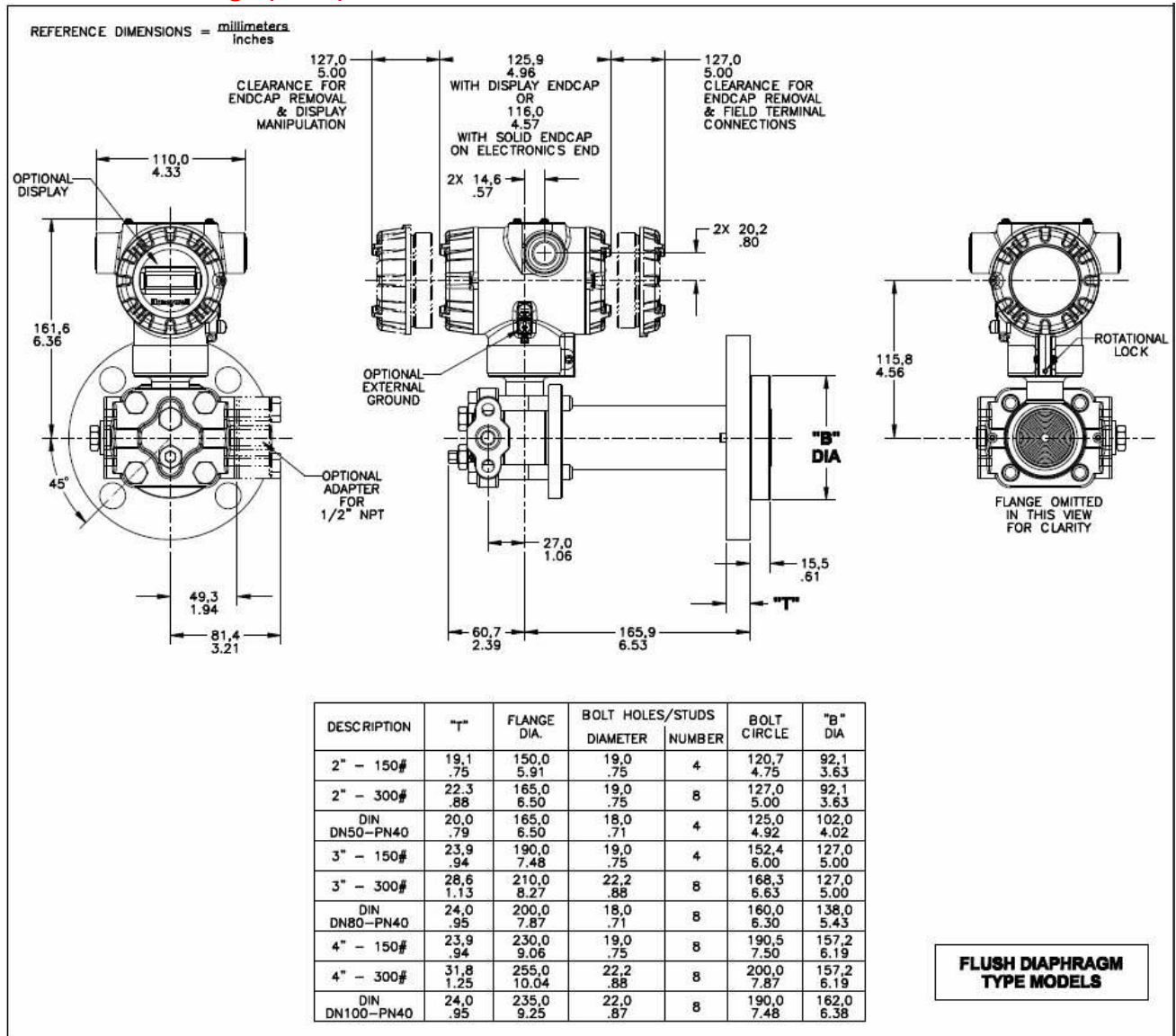

Figure 4 – Typical mounting dimensions for flush diaphragm type models STF724 and STF732.



## Dimensional Drawings (con't)

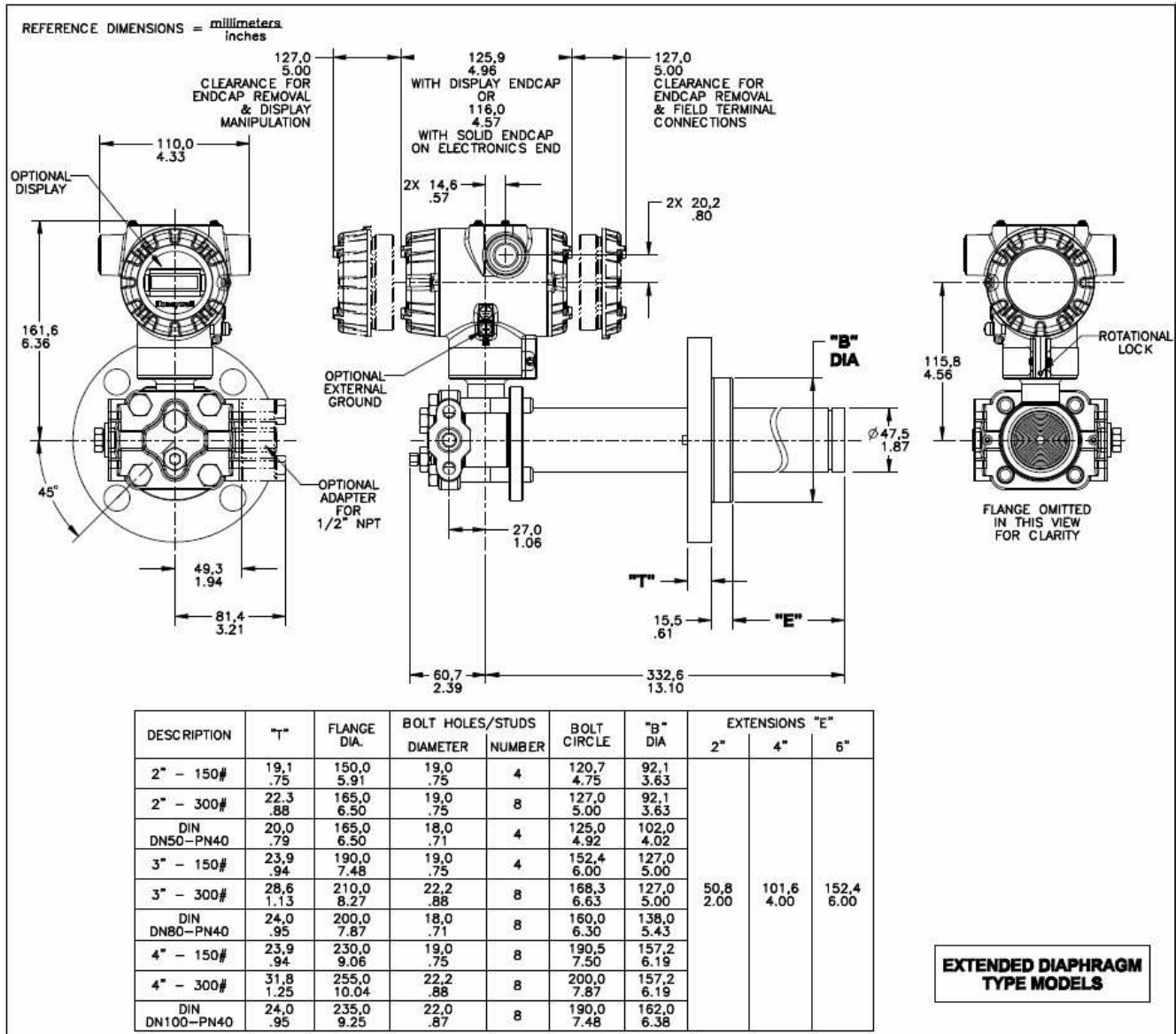

Figure 5 – Typical mounting dimensions for extended diaphragm type models STF724 and STF732.

## Dimensional Drawings (con't)

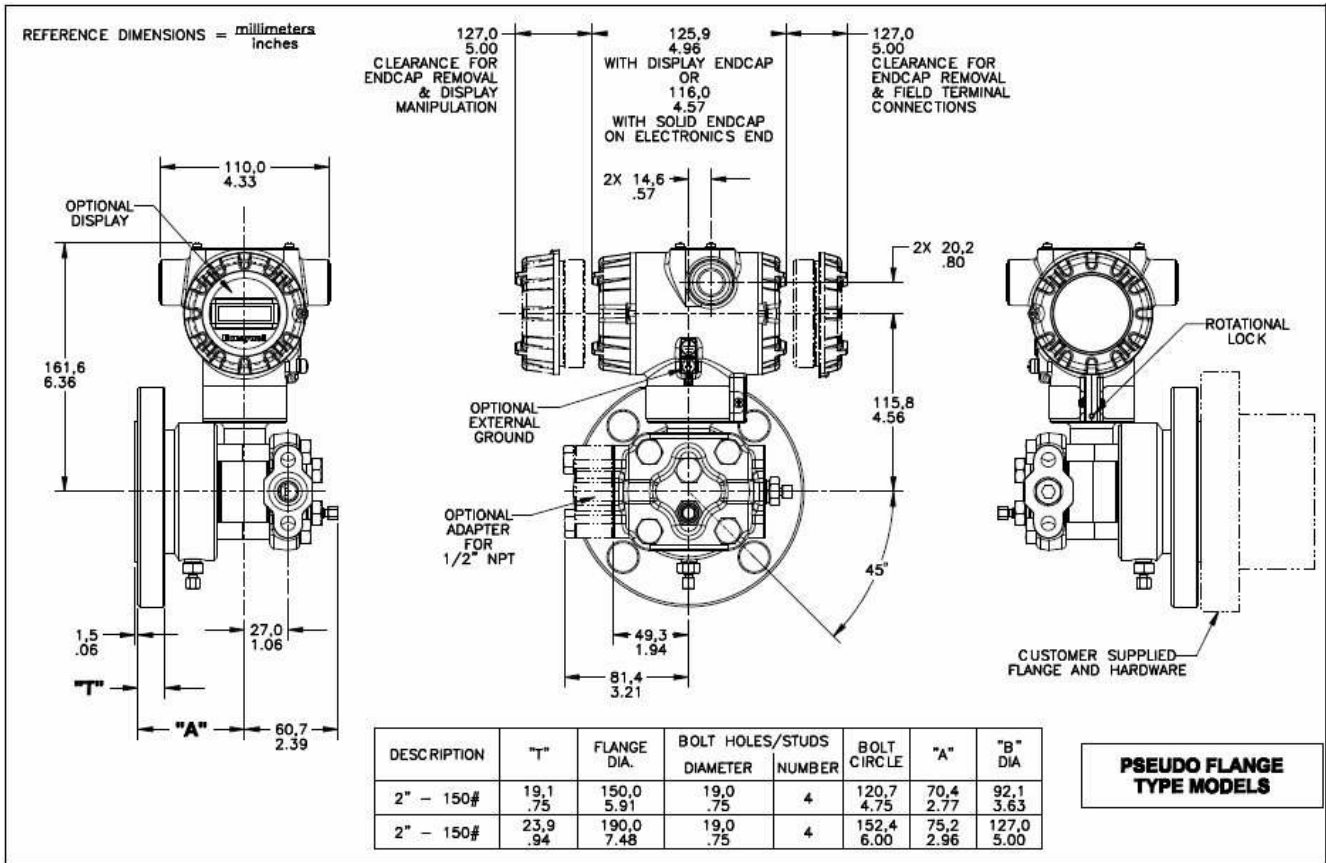

Figure 6 – Typical mounting dimensions for pseudo flange type models STF72F, STF73F, and STF74F.

## Model Selection Guide

Model Selection Guides are subject to change and are inserted into the specifications as guidance only.

# Model STF700 Flange Mounted Liquid Level Transmitter

Model Selection Guide  
34-ST-16-103 Issue 21

Instructions									
<ul style="list-style-type: none"> <li>Select the desired Key Number. The arrow to the right marks the selection available.</li> <li>Make one selection from each Table (I, II and IX) using the column below the proper arrow.</li> <li>A(●) denotes unrestricted availability. A letter denotes restricted availability.</li> <li>Restrictions follow Table IX.</li> </ul>									
Key Number	I	II	III	IV	V	VI	VII	VIII	IX
STF7 ___	- [ ] -	[ ] -	[ ] -	[ ] -	[ ] -	[ ] -	[ ] -	[ ] -	+ 0 0 0 0

KEY NUMBER	URL	LRL	Max Span	Min Span	Units	Selection	Availability
Measurement Range Std	400 (1000)	-400 (-1000)	400 (1000)	4 (10)	" H <sub>2</sub> O (mbar)	STF724	↓
	100 (7)	-100 (-7)	100 (7)	1 (0.07)	psi (bar)	STF732	↓
Accuracy	400 (1000)	-400 (-1000)	400 (1000)	1 (2.5)	" H <sub>2</sub> O (mbar)	STF72F	↓
	100 (7)	-100 (-7)	100 (7)	1 (0.07)	psi (bar)	STF73F	↓

TABLE I	Materials of Construction	Design	Ref. Head	Vent Drain Valve on Ref. Head <sup>2</sup>	Barrier Diaphragm. (wetted)	Diaphragm. Plate (wetted)	Extension (wetted)	Sel.			
Meter Body & Flange Design	a. Process Wetted Heads & Diaphragm Materials	Flush	Carbon <sup>1</sup> Steel	316 SS	316L SS	316L SS	N/A	A	●		
					Hast C <sup>3</sup>	316L SS		W	●		
					Hast C <sup>3</sup>	Hast C <sup>3</sup>		B	●		
			316 SS <sup>5</sup>		316L SS	316L SS		E	●		
					Hast C <sup>3</sup>	316L SS		X	●		
					Hast C <sup>3</sup>	Hast C <sup>3</sup>		F	●		
			Hast C <sup>3,6</sup>	Hast C <sup>3</sup>	Hast C <sup>3</sup>	Hast C <sup>3</sup>		J	●		
			Extended	Carbon <sup>1</sup> Steel	316 SS	316L SS	316L SS	316L SS	M	●	
				Hast C <sup>3</sup>		Hast C <sup>3</sup>			N	●	
			316 SS <sup>5</sup>		316L SS		R	●			
					Hast C <sup>3</sup>		S	●			
		Pseudo Flange	Carbon <sup>1</sup> Steel	316 SS	316L SS	N/A	N/A	1	●		
			Hast C <sup>3</sup>		Hast C <sup>3</sup>			2	●		
			316 SS <sup>5</sup>		316L SS			4	●		
					Hast C <sup>3</sup>			5	●		
		b. Fill Fluid (Meter Body & Flange)	Silicone Oil 200					1	●	●	
			Fluorinated Oil CTFE					2	●	●	
			Silicone Oil 704					3	●	●	
			NEOBEE® M-20					4	●	●	
		c. Process Connection	Reference Head			Flange		Sel.			
			1/4 NPT			High Pressure Side	A	●	●		
						Low Pressure Side	C	●	●		
			1/2 NPT Adapter - material matches head material and head bolt material <sup>11</sup>			High Pressure Side	H	●	●		
						Low Pressure Side	K	●	●		
	d. Bolts for Process Heads	Carbon Steel Bolts					C	●	●		
		316 SS Bolts					S	●	●		
		A286 SS (NACE) Bolts					N	●	●		
		B7M Bolts					B	●	●		
	e. Vent/Drain Type/Location	Ref. Head Type	Vent Type	Location	Vent Material		Sel.				
		Single Ended	None	None	None		1	●	●		
		Single Ended	Std	Side	Matches Head Material <sup>11</sup>		2	●	●		
		Single Ended	Ctr	Side	Stainless Steel Only		3	t	t		
		Dual Ended	Std	End	Matches Head Material <sup>11</sup>		4	●	●		
		Dual Ended	Cntr	End	Stainless Steel Only		5	t	t		
	Dual Ended	Vent/Plug	Side/End	Matches Head Material <sup>11</sup>		6	●	●			
	f. Gasket Material	Teflon® or PTFE (Glass Filled)					A	●	●		
		Viton® or Fluorocarbon Elastomer					B	●	●		

<sup>1</sup> Carbon Steel heads are zinc-plated and not recommended for water service due to hydrogen migration. For that service, use the 316 stainless steel Wetted Reference Head.

<sup>2</sup> Vent/Drains are Teflon or PTFE coated for lubricity.

<sup>3</sup> Hastelloy® C-276 or UNS N10276

<sup>5</sup> Supplied as 316 SS or as Grade CF8M, the casting equivalent of 316 SS.

<sup>6</sup> Supplied as indicated or as Grade CW12MW, the casting equivalent of Hastelloy® C-276

<sup>11</sup> Except Carbon Steel Heads shall use 316SS Vent/Drain, Flugs & Adapters when required

TABLE II		Flange Material	Threaded Nut Ring Material	Selection	Availability			
					24	2F		
					32	3F		
Flange Assembly	a. Flange (ANSI Flanges have 125-500 AARH Surface Finish)	3" ANSI Class 150 3" ANSI Class 300 DN80-PN40 DIN 4" ANSI Class 150 4" ANSI Class 300 DN100-PN40 DIN 2" ANSI Class 150 2" ANSI Class 300 DN50-PN40 DIN	Carbon Steel (non-wetted)	Carbon Steel (non-wetted)	1 __ 2 __ 3 __ 4 __ 5 __ 6 __ 7 __ 8 __ 9 __	• • • • • • • • •		
		3" ANSI Class 150 3" ANSI Class 300 DN80-PN40 DIN 4" ANSI Class 150 4" ANSI Class 300 DN100-PN40 DIN 2" ANSI Class 150 2" ANSI Class 300 DN50-PN40 DIN	304 SS (non-wetted)	304 SS (non-wetted)	A __ B __ C __ D __ E __ F __ Q __ U __ V __	• • • • • • • • •		
		3" ANSI Class 150 3" ANSI Class 300 DN80-PN40 DIN 4" ANSI Class 150 4" ANSI Class 300 DN100-PN40 DIN 2" ANSI Class 150 2" ANSI Class 300 DN50-PN40 DIN	316 SS (non-wetted)	304 SS (non-wetted)	H __ J __ K __ L __ M __ N __ W __ X __ Z __	• • • • • • • • •		
		Pseudo Flange on Standard DP				Sel.		
		b. Gasket Ring (wetted)	No Selection			S __		•
			Flush Design		316L SS Hastelloy® C <sup>3</sup>	_1 _2	s	
		c. Extension (wetted)	Extended Design		316L SS	_5	v	
			No Selection			_0		•
			Flush			_F	w	
			Diameter	Length	Sel.			
		1.87 Inches (for 2", 3" or 4" spud) <sup>13</sup>	2 inches 4 inches 6 inches	_C _D _E	v v v			

<sup>3</sup> Hastelloy® C-276 or UNS N10276

<sup>13</sup> For part numbers and pricing information on Tank Spuds refer to page ST-91 (Supplementary Accessories & Kits).

TABLE III		Agency Approvals (see data sheet for Approval Code Details)	Selection		
Approvals	No Approvals Required		0	*	*
	FM Explosion proof, Intrinsically Safe, Non-incendive, & Dustproof		A	*	*
	CSA Explosion proof, Intrinsically Safe, Non-incendive, & Dustproof		B	*	*
	ATEX Explosion proof, Intrinsically Safe & Non-incendive		C	*	*
	IECEX Explosion proof, Intrinsically Safe & Non-incendive		D	*	*
	SAEx Explosion proof, Intrinsically Safe & Non-incendive		E	*	*
	INMETRO Explosion proof, Intrinsically Safe & Non-incendive		F	*	*
	NEPSI Explosion proof, Intrinsically Safe & Non-incendive		G	*	*
	KOSHA Explosion proof, Intrinsically Safe & Non-incendive		H	*	*
	EAC Customs Union(Russia,Belarus,Kazakhstan) Ex Approval,Flame proof, Intrinsically Safe		I	*	*
	CCoE Explosion proof, Intrinsically Safe & Non-incendive		J	*	*
UATR Flameproof, Intrinsically Safe & Dustproof		K	*	*	

TABLE IV		TRANSMITTER ELECTRONICS SELECTIONS			Selection		
a. Electronic Housing Material & Connection Type	Material	Connection	Lightning Protection				
	Polyester Powder Coated Aluminum	1/2 NPT	None	A __	*	*	
	Polyester Powder Coated Aluminum	M20	None	B __	*	*	
	Polyester Powder Coated Aluminum	1/2 NPT	Yes	C __	*	*	
	Polyester Powder Coated Aluminum	M20	Yes	D __	*	*	
	316 Stainless Steel (Grade CF8M)	1/2 NPT	None	E __	*	*	
	316 Stainless Steel (Grade CF8M)	M20	None	F __	*	*	
	316 Stainless Steel (Grade CF8M)	1/2 NPT	Yes	G __	*	*	
316 Stainless Steel (Grade CF8M)	M20	Yes	H __	*	*		
b. Output/ Protocol	Analog Output		Digital Protocol				
	4-20mA dc		HART Protocol	_H	*	*	
	4-20mA dc none		DE Protocol Foundation Fieldbus	_D _F	*	*	
c. Customer Interface Selections	Indicator	Ext Zero, Span & Config Buttons	Languages				
	None	None	None	_0	*	*	
	None	Yes (Zero/Span Only)	None	_A	f	f	
	Basic	None	English	_B	*	*	
	Basic	Yes	English	_C	*	*	
Standard (w/Internal Zero, Span & Conf Buttons)	None	English	_D	u	u		

Availability  
STF7xx

TABLE V	CONFIGURATION SELECTIONS			Selection	24	2F
a. Application Software	Diagnostics				32	3F
	Standard Diagnostics			1 _ _	*	*
b. Output Limit, Failsafe & Write Protect Settings	Write Protect	Fail Mode	High & Low Output Limits <sup>3</sup>			
	Disabled	High> 21.0mAdc	Honeywell Std (3.8 - 20.8 mAdc)	_ 1 _	f	f
	Disabled	Low< 3.6mAdc	Honeywell Std (3.8 - 20.8 mAdc)	_ 2 _	f	f
	Enabled	High> 21.0mAdc	Honeywell Std (3.8 - 20.8 mAdc)	_ 3 _	f	f
	Enabled	Low< 3.6mAdc	Honeywell Std (3.8 - 20.8 mAdc)	_ 4 _	f	f
	Enabled	N/A	N/A Fieldbus	_ 5 _	g	g
	Disabled	N/A	N/A Fieldbus	_ 6 _	g	g
c. General Configuration	Factory Standard			_ _ S	*	*
	Custom Configuration (Unit Data Required from customer)			_ _ C	*	*

<sup>3</sup> NAMUR Output Limits 3.8 - 20.5mAdc can be configured by the customer or select custom configuration Table Vc

TABLE VI	CALIBRATION & ACCURACY SELECTIONS			Selection		
Accuracy and Calibration	Accuracy	Calibrated Range	Calibration Qty			
	Standard	Factory Std	Single Calibration	A	*	*
	Standard	Custom (Unit Data Required)	Single Calibration	B	*	*
	High Accuracy	Factory Std	Single Calibration	E	h	h
	High Accuracy	Custom (Unit Data Required)	Single Calibration	F	h	h

TABLE VII	ACCESSORY SELECTIONS			Selection		
a. Mounting Bracket	None (not required with flange mount unit)			0 _ _	*	*
	b. Customer Tag	No customer tag			_ 0 _ _	*
One Wired Stainless Steel Tag (Up to 4 lines 26 char/line)			_ 1 _ _	*	*	
Two Wired Stainless Steel Tag (Up to 4 lines 26 char/line)			_ 2 _ _	*	*	
c. Unassembled Conduit Plugs & Adapters	No Conduit Plugs or Adapters Required			_ _ A0	*	*
	1/2 NPT Male to 3/4 NPT Female 316 SS Certified Conduit Adapter			_ _ A2	n	n
	1/2 NPT 316 SS Certified Conduit Plug			_ _ A6	n	n
	M20 316 SS Certified Conduit Plug			_ _ A7	m	m
	Minifast <sup>®</sup> 4 pin (1/2 NPT)			_ _ A8	n	n
	Minifast <sup>®</sup> 4 pin (M20)			_ _ A9	m	m

TABLE VIII	OTHER Certifications & Options: (String in sequence comma delimited (XX, XX, XX,....))	Selection		
Certifications & Warranty	None - No additional options	00	*	*
	NACE MR0175; MR0103; ISO15156 (FC33338) Process wetted parts only	FG	*	*
	NACE MR0175; MR0103; ISO15156 (FC33339) Process wetted and non-wetted parts	F7	c	c
	Marine (DNV, ABS, BV, KR, LR)	MT	i	i
	EN10204 Type 3.1 Material Traceability (FC33341)	FX	*	*
	Certificate of Conformance (F3391)	F3	*	*
	Calibration Test Report & Certificate of Conformance (F3399)	F1	*	*
	Certificate of Origin (F0195)	F5	*	*
	FMEDA (SIL 2/3) Certification (FC33337)	FE	j	j
	Over-Pressure Leak Test Certificate (1.5X MAWP) (F3392)	TP	*	*
	Cert Clean for O <sub>2</sub> or CL <sub>2</sub> service per ASTM G93	OX	e	e
	PMI Certification	PM	*	*
	Extended Warranty Additional 1 year	01	*	*
	Extended Warranty Additional 2 years	02	*	*
Extended Warranty Additional 3 years	03	*	*	
Extended Warranty Additional 4 years	04	*	*	

TABLE IX	Manufacturing Specials			
Factory	Factory Identification	0000	*	*

**MODEL RESTRICTIONS**

Restriction Letter	Available Only with		Not Available with	
	Table	Selection(s)	Table	Selection(s)
b	Select only one option from this group			
c	ld	___ N,B ___		
e	lb	__ 2 ___		
f			IVb	__ F __
g			IVb	__ H,D ___
h	la	A, E, M, R, 1, 4 ___		
i	IVa	C,D,G,H ___		
j	IVb	__ H __	Vb	__ 1,2,5,6, __
m	IVa	B,D,F,H ___		
n	IVa	A,C,E,G ___		
s	la	A,W,B,E,X,F,J ___		
t			la	J ___
u	IVb	__ H __		
v	la	M,N,R,S ___		
w			la I Ib	M,N,R,S __ 5 __

<sup>1</sup>The PM option is available on all Smartline Pressure Transmitter process wetted parts such as process heads, flanges, bushings and vent plugs except plated carbon steel process heads and flanges. PM option information is also available on diaphragms except STG and STA in-line construction pressure transmitters.

**FIELD INSTALLABLE REPLACEMENT PARTS**

Description	Kit Number
Integrally Mounted Basic Indicator Kit (Compatible with all Electronic Modules)	50049911-501
Terminal Strip w/Lightning Protection Kit for HART or DE Modules	50075472-532
Terminal Strip w/Lightning Protection Kit for FFB Module	50075472-534
Terminal Strip w/o Lightning Protection for HART or DE Modules	50075472-531
Terminal Strip w/o Lightning Protection FFB Module	50075472-533
HART Electronics Module	50049849-501
HART Electronics Module w/connection for external configuration buttons	50049849-502
DE Electronics Module	50049849-503
DE Electronics Module w/connection for external configuration buttons	50049849-504
FFB Electronics Module Kit	50049849-509
FFB Electronics Module w/connection for external configuration buttons	50049849-510
Standard Display Module	50126003-501

**PRODUCT MANUALS**

Description	Part Number
ST 700 SmartLine Transmitter User Manual - English	34-ST-25-44
ST 700 SmartLine Transmitter HART/DE Communications Manual - English	34-ST-25-47
ST 700 SmartLine Transmitter Safety Manual - English	34-ST-25-37
ST 700 SmartLine Transmitter Foundation Fieldbus Manual - English	34-ST-25-48
Paper Manual ST 700 Smart Transmitter Function Block Manual - English	34-ST-25-49

All product documentation is available at [www.honeywellprocess.com](http://www.honeywellprocess.com).

Hastelloy® is a registered trademark of Haynes International  
HART® is a registered trademark of HART Communication Foundation.  
FOUNDATION™ Fieldbus is a trademark of Fieldbus Foundation.  
Viton® is a registered trademark of DuPont Performance Elastomers.  
Teflon® is a registered trademark of DuPont.  
FM Approvals<sup>SM</sup> is a service mark of FM Global  
DC® 200 is a registered trademark of Dow Corning

## Sales and Service

For application assistance, current specifications, ordering, pricing, and name of the nearest Authorized Distributor, contact one of the offices below.

### ASIA PACIFIC

Honeywell Process Solutions,  
Phone: + 800 12026455 or  
+44 (0) 1202645583  
(TAC) [hfs-tac-support@honeywell.com](mailto:hfs-tac-support@honeywell.com)

#### Australia

Honeywell Limited  
Phone: +(61) 7-3846 1255  
FAX: +(61) 7-3840 6481  
Toll Free 1300-36-39-36  
Toll Free Fax:  
1300-36-04-70

#### China – PRC - Shanghai

Honeywell China Inc.  
Phone: (86-21) 5257-4568  
Fax: (86-21) 6237-2826

#### Singapore

Honeywell Pte Ltd.  
Phone: +(65) 6580 3278  
Fax: +(65) 6445-3033

#### South Korea

Honeywell Korea Co Ltd  
Phone: +(822) 799 6114  
Fax: +(822) 792 9015

### EMEA

Honeywell Process Solutions,  
Phone: + 800 12026455 or  
+44 (0) 1202645583

#### Email: (Sales)

[FP-Sales-Apps@Honeywell.com](mailto:FP-Sales-Apps@Honeywell.com)

or

(TAC)

[hfs-tac-support@honeywell.com](mailto:hfs-tac-support@honeywell.com)

#### Web

Knowledge Base search  
engine <http://bit.ly/2N5Vldi>

### AMERICAS

Honeywell Process Solutions,  
Phone: (TAC) (800) 423-9883  
or (215) 641-3610  
(Sales) 1-800-343-0228

#### Email: (Sales)

[FP-Sales-Apps@Honeywell.com](mailto:FP-Sales-Apps@Honeywell.com)

or

(TAC)

[hfs-tac-support@honeywell.com](mailto:hfs-tac-support@honeywell.com)

#### Web

Knowledge Base search  
engine <http://bit.ly/2N5Vldi>

*Specifications are subject to change without notice.*

### For more information

To learn more about SmartLine Pressure  
Transmitters visit [www.honeywellprocess.com](http://www.honeywellprocess.com)  
Or contact your Honeywell Account Manager

### Process Solutions

Honeywell  
1250 W Sam Houston Pkwy S  
Houston, TX 77042

Honeywell Control Systems Ltd  
Honeywell House, Skimped Hill Lane  
Bracknell, England, RG12 1EB

Shanghai City Centre, 100 Jungi Road  
Shanghai, China 20061

[www.honeywellprocess.com](http://www.honeywellprocess.com)



34-ST-03-103  
July 2020

©2020 Honeywell International Inc.