

RER 101-36/18 NHH

DC centrifugal compact fan

single-intake



ebm-papst St. Georgen GmbH & Co. KG

Hermann-Papst-Str. 1
D-78112 St. Georgen
Phone +49 (0) 7724 81-0
Fax +49 (0) 7724 81-1309
info2@de.ebmpapst.com
www.ebmpapst.com

Nominal data

Type	RER 101-36/18 NHH	
Nominal voltage	VDC	48
Nominal voltage range	VDC	36 .. 60
Speed (rpm)	min ⁻¹	5850
Power consumption	W	19.4
Min. ambient temperature	°C	-20
Max. ambient temperature	°C	70
Air flow	m ³ /h	190
Sound power level	B	7.2

ml = Max. load · me = Max. efficiency · fa = Free air · cs = Customer specification · ce = Customer equipment
Subject to change



Technical description

General description	Backward-curved impeller
Weight	0.305 kg
Dimensions	Ø 101 x 52 mm
Impeller material	Glass-fiber reinforced plastic
Housing material	Scroll housing made of glass-fiber reinforced plastic.
Airflow direction	Axial: intake, radial: discharge
Direction of rotation	Clockwise, viewed toward rotor
Storage	Ball bearing
Service life L10 at 40 °C	60000 h
Service life L10 at maximum temperature	30000 h
Cable	With leads AWG 22, TR 64
Motor protection	Protection against reverse polarity and blocked rotor.
Option	Alarm signal

Product drawing

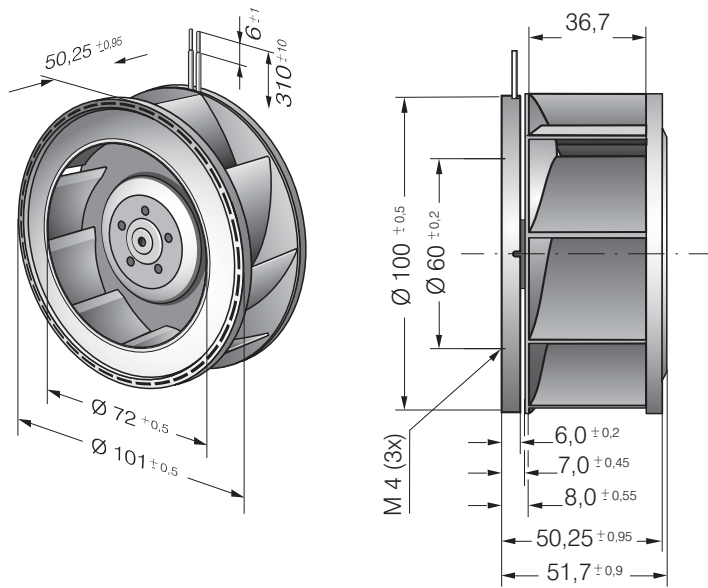

Curves: Air performance

