

VM SERIES 1000-1300 MM

The DENSO VM-Series six-axis articulated robots offer exceptionally long reaches along with high speed, high precision and a large payload capacity. The VM-Series robots offer the following outstanding features:

- Fast cycle times from 0.95 to 0.89 sec.
- Payloads up to 10 kg
- Reaches from 1,000 mm to 1,300 mm
- High maximum allowable moment of inertia
- Compact design saves floor space, facilitates integration
- Floor- or ceiling-mount, with no special hardware required
- Operation in dusty and wet environments (optional IP65 configuration)
- Operation in cleanrooms (optional cleanroom class-100 configuration)
- ANSI and CE compliance allows global deployment



VM-6083G



VM-60B1G



CEILING-MOUNT OPTION



	VM-6083G	VM-60B1G
Number of axes	6	
Overall arm length (mm)	830	1,110
Second-arm width (mm)	130	
Reach (to center of 5th axis, mm)	1,021	1,298
Minimum motion area (mm)	393	404
Maximum payload (kg)	10	
Weight, approx. (kg)	82	
Footprint (mm)	300 × 300	
Cycle time (sec.)	0.89 (with 5-kg weight)	0.95 (with 5-kg weight)
Maximum composite speed (mm/sec.)	8,300	
Maximum joint speed (°/sec.)	J1: 225 J2: 168 J3: 187 J4, J5: 375 J6: 600	
Repeatability ^{1,2} (mm)	±0.05	±0.07
Maximum allowable moment of inertia (kgm ²)	J4, J5: 0.36 J6: 0.064	
Range of motion (°)	J1: ±170 J2: +135, -90 J3: +165, -80 J4: ±185 J5: ±120 J6: ±360	
Position detection	Absolute encoder	
Drive motors and brakes	AC servomotors for all axes; brakes on 2nd, 3rd, 4th, 5th and 6th axis	
Air piping (in-arm integrated)	7 systems (ø4 × 6, ø6 × 1), three 2-position double solenoid valves	
Wiring (in-arm integrated)	10 lines (max 1 A per line)	
Protection class	Standard: IP40 Options: IP54/65 (body/wrist), cleanroom class 100 (0.3 µm)	
Ceiling-mount ³	✓	

1. At constant ambient temperature. 2. In all directions. 3. All except cleanroom models, which can be floor-mounted only.



Scan this QR Code®
for more information

VM SERIES 1000-1300 MM

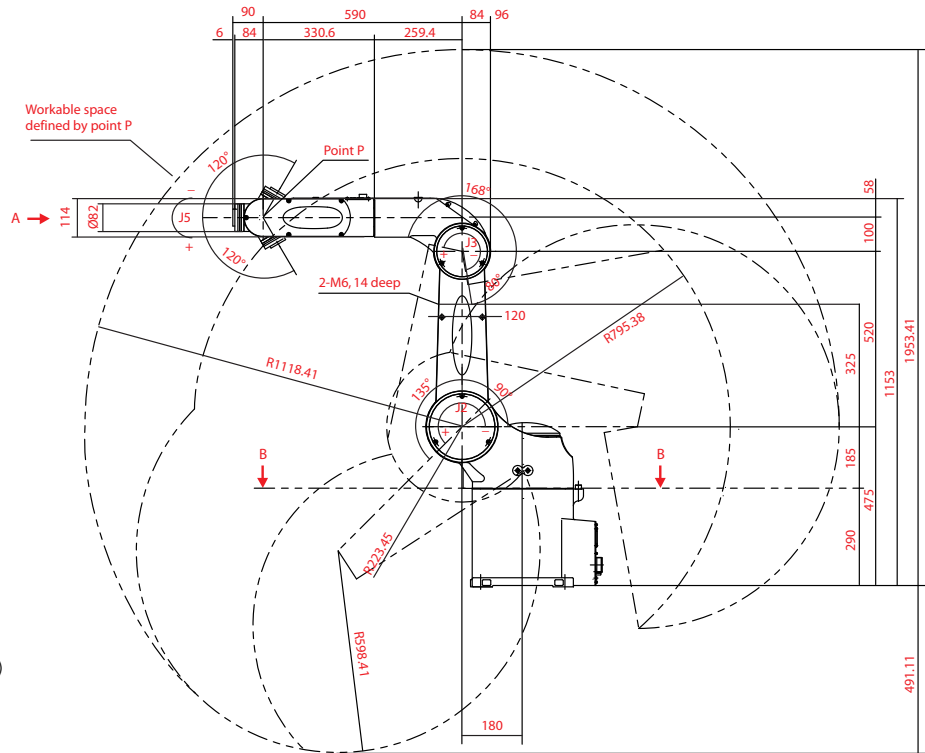

Detail of end-effector mounting face (view A)

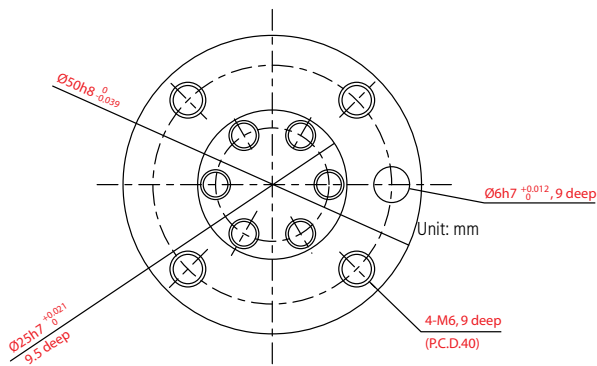

Detail of base mounting face (view B-B)

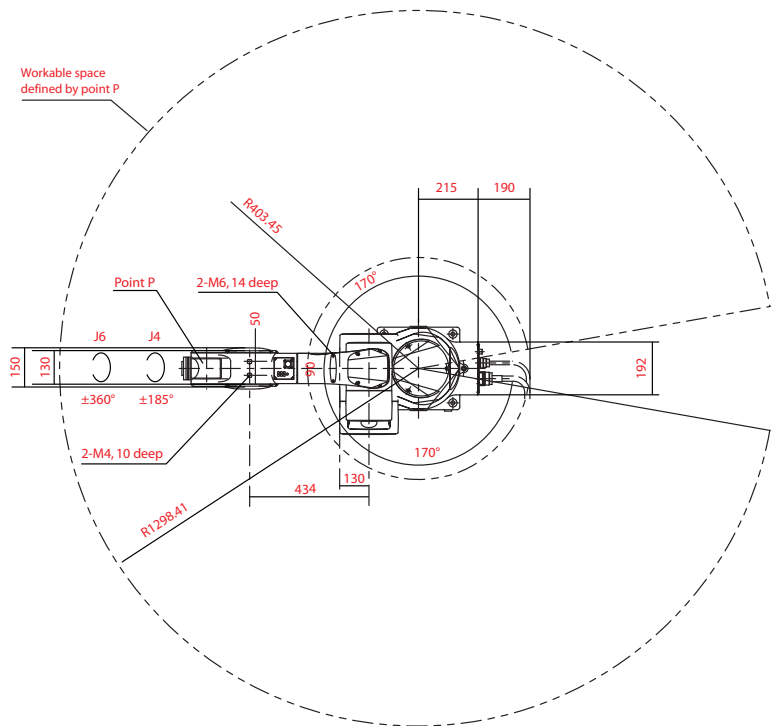
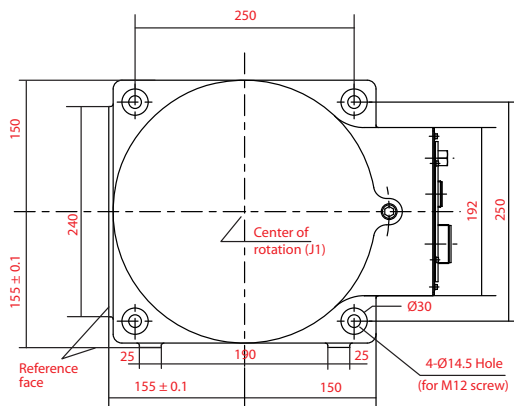

DENSO ROBOTICS

3900 Via Oro Avenue, Long Beach, California 90810, U.S.A

Tel: 888-4-ROBOTX (888-476-2689) | Fax: (310) 952-7502 | info@densorobotics.com

© 2014 DENSO Corporation

Information subject to change without notice

QR Code® is a registered trademark of DENSO WAVE INCORPORATED. All rights reserved.

DENSO
robotics

www.densorobotics.com