

MICRO SWITCH™ Standard Basic Switches

V15 Series

004945

Issue 8

Datasheet



DESCRIPTION

Honeywell's MICRO SWITCH™ V-Basic Standard Switch, V15 Series is an electromechanical switch designed to provide outstanding value in a reliable global package. This switch is often ideal for “low-cost-of-failure” applications, where the cost is minimal to replace or service any failure related to the switch. With a wide variety of operating forces, and amperage ratings, the V15 is designed for numerous types of applications.

Available in both pin plunger and levered styles, the V15 Series also offers a multitude of termination styles to fit almost any application.

VALUE TO CUSTOMERS

- Wide choice of electrical ratings: 0.1 A, 5 A, 10 A, 16 A, 22 A, 26 A
- Certified for global use: UL/cUL, ENEC, CQC
- Available with pin plungers or integral levers to meet multiple application and equipment requirements

DIFFERENTIATION

- Choice of actuation, termination, and operating characteristics that can allow for flexibility in numerous types of applications
- With a broad current capacity, one switch package can control a wide range of electrical loads

FEATURES

- Broad range of electrical loads: 0.1 A, 5 A, 10 A, 16 A, 22 A, 26 A
- Long service life: over one million mechanical operations
- Gold contacts are also available for controlling logic level/low energy circuits
- World-wide package size acceptance
- UL/CSA, cUL, ENEC, and CQC approvals

POTENTIAL APPLICATIONS

- Appliances
- Furnaces
- Gaming machines
- Ice makers
- Power washers
- Vending machines

PORTFOLIO

Honeywell offers a broad range of MICRO SWITCH™ basic switches including large, V-Basic, miniature, watertight, and special application switches.

MICRO SWITCH™ Standard Basic Switches, V15 Series

Table 1. Specifications

Characteristic	Parameter
Circuitry	SPDT, SPNO, SPNC
Operating force	0,15 N to 3,92 N [15g to 400 g]
Termination	quick connect; 6,35 mm x 0,80 mm [0.250 in x 0.032 in] quick connect 4,80 mm x 0,80 mm [0.187 in x 0.032 in] quick connect 4,80 mm x 0,50 mm [0.187 in x 0.020 in] push-in terminals; RAST-5 250#; RAST-7 250#; short solder; slot-hole solder; solder; right side PCB; left side PCB; straight PCB; screw; oblique screw
Actuators	pin plunger, integral lever options
Agency certification	ENEC, CQC, UL, cUL
Operating temperature (manufacturer specified)	code S: -25 °C to 85 °C [-13 °F to 185 °F] code T: -25 °C to 125 °C [-13 °F to 257 °F] code H: -25 °C to 150 °C [-13 °F to 302 °F]
Mechanical life (cycles)	1 million cycles (except for 200g versions of V15S05 and V15T10 which are 500,000 cycles)
Contact material	silver, gold-plated
Housing material	PBT thermoplastic polyester (standard) PET thermoplastic polyester (V15H high temperature, 150 °C [302 °F])

Table 2. Electrical Ratings

Rating/Nomenclature Code	UL/cUL (CUL 61058-1, File 12252) Americas	ENEC (IEC 61058-1) Europe CQC (GB15092-1) Asia-Pacific
05	5 GPA 125/250 Vac; 0.1 GPA 125/250 Vac 1/10 HP 125/250 Vac 0.1 RA 48 Vdc 10,000 cycles	0.1 A 125/250 Vac; 0.1 A 48 Vdc 5 (2.5) A 125/250 Vac 50,000 cycles
H10	10 GPA 125/250 Vac 1/2 HP 125/250 Vac 1.0 RA 30 Vdc 100,000 cycles	n/a
T10	11 GPA 125/250 Vac 1/3 HP 125/250 Vac 0.5 RA 125 Vdc 0.25 RA 250 Vdc 10,000 cycles	0.5 A 125 Vdc; 0.25 A 250 Vdc 10 (3) A 125/250 Vac 50,000 cycles
S11	11 (3) 125/250 Vac 50,000 cycles	11 (3) 125/250 Vac 50,000 cycles (ENEC only)
16	16 GPA 125/250 Vac 1/2 HP 125/250 Vac 10,000 cycles	16 (4) A 250 Vac 50,000 cycles
22	22 GPA 125/250 Vac 1 HP 125/250 Vac 10,000 cycles	22 (8) A 250 Vac 25,000 cycles
26	n/a	0.02 A 250 Vac 26 (10) A 250 Vac 50,000 cycles

- RA = Resistive Amps (Resistive Load)
- GPA = General Purpose Amps (Inductive Load, 75 % to 80 % power factor)
- VL = Lamp Load

- XX (Y) = XX max. resistive value (Amps) and (Y) max. inductive value (Amps)

MICRO SWITCH™ Standard Basic Switches, V15 Series

V15S05 PRODUCT NOMENCLATURE

V15	S	05	—	C	1	Z	200	A	06	—	K	A			
Switch Type	Temperature Grade	Electrical Rating		Terminal Type	Housing Type	Circuit Code	Operating Force (at pin plunger max)	Lever Position	Lever Type		Mounting Holes	Special Designator			
V15 Series Standard Basic Switch	S 85 °C [185 °F] (for "05" and "11" ratings only)	05 0.1 A 48 Vdc/ 125 Vac/250 Vac 5 A 125 Vac/250 Vac	—	C Quick connect 6.30 mm x 0.80 mm [0.250 in x 0.032 in]	Basic (blank)	Z SPDT	200 200 gf; 1.96 N	A Pin plunger, no lever (blank)	No Lever (blank)	—	Metric Ø 3.1 mm (blank)	A Special Designator A special designator letter is used only when there is a special modification to the switch. Review Product Specification to determine the exact differences. Below is an example. A Contact gold-plated			
				D Quick connect 4.70 mm x 0.80 mm [0.187 in x 0.032 in]		1 Flat			P SPST-NO				015 15 gf; 0.15 N	A Far from pin plunger	01 Short straight lever
				E Quick connect 4.70 mm x 0.50 mm [0.187 in x 0.020 in]		2 Fully flat			C SPST-NC				025 25 gf; 0.25 N	B Near pin plunger	02 Standard straight lever
				F Screw terminal w/ pressure plate									050 50 gf; 0.49 N		03 Long straight lever
U Push-in terminal (used only in combination with "S1")						100 100 gf; 0.96 N		04 Simulated roller lever							
		11* 11 A 125 Vac/250 Vac							06 Long roller lever						
									** Special						

* Type "11" rating only available with U terminal type and 200 gf operating force.
** Additional code assigned for specials

V15T10 PRODUCT NOMENCLATURE

V15	T	10	—	C	1	Z	200	A	06	—	K	A			
Switch Type	Temperature Grade	Electrical Rating		Terminal Type	Housing Type	Circuit Code	Operating Force (at pin plunger max)	Lever Position	Lever Type		Mounting Holes	Special Designator			
V15 Series Standard Basic Switch	T 125 °C [257 °F]	10 0.5 A 125 Vdc 0.25 A 250 Vdc 4 A 125 Vac (lamp load) 10 A 125 Vac/250 Vac	—	C Quick connect 6.30 mm x 0.80 mm [0.250 in x 0.032 in]	Basic (blank)	Z SPDT	200 200 gf; 1.96 N	A Pin plunger, no lever (blank)	No Lever (blank)	—	Metric Ø 3.1 mm (blank)	A Special Designator A special designator letter is used only when there is a special modification to the switch. Review Product Specification to determine the exact differences. Below is an example. A Contact gold-plated			
				D Quick connect 4.70 mm x 0.80 mm [0.187 in x 0.032 in]		1 Flat			P SPST-NO				050 50 gf; 0.49 N	A Far from pin plunger	01 Short straight lever
				E Quick connect 4.70 mm x 0.50 mm [0.187 in x 0.020 in]		2 Fully flat			C SPST-NC				100 100 gf; 0.96 N	B Near pin plunger	02 Standard straight lever
				F Screw terminal w/ pressure plate									200 200 gf; 1.96 N		03 Long straight lever
									04 Simulated roller lever						
									05 Roller lever						
									06 Long roller lever						
									** Special						

** Additional code assigned for specials

V15H16/T16/T22/H22/T26 PRODUCT NOMENCLATURE

V15	H	16	—	C	1	Z	200	A	06	—	K	A	
Switch Type	Temperature Grade	Electrical Rating		Terminal Type	Housing Type	Circuit Code	Operating Force (at pin plunger max)	Lever Position	Lever Type		Mounting Holes	Special Designator	
V15 Series Standard Basic Switch	T 125 °C [257 °F]	10 1 A 30 Vdc 10 A 1/2 HP 125/250 Vac (at temperature grade only)	—	C Quick connect 6.30 mm x 0.80 mm [0.250 in x 0.032 in]	Basic (blank)	Z SPDT	200 200 gf; 1.96 N	A Pin plunger, no lever (blank)	No Lever (blank)	—	Metric Ø 3.1 mm (blank)	A Special Designator A special designator letter is used only when there is a special modification to the switch. Review Product Specification to determine the exact differences. Below is an example. A Contact gold-plated	
				D Quick connect 4.70 mm x 0.80 mm [0.187 in x 0.032 in]		1 Flat			P SPST-NO				100 100 gf; 0.96 N
	H 150 °C [302 °F]	16 16 A 125 Vac/250 Vac	—	E Quick connect 4.70 mm x 0.50 mm [0.187 in x 0.020 in]	2 Fully flat	C SPST-NC	300 300 gf; 2.84 N	B Near pin plunger		02 Standard straight lever			
				F Screw terminal w/ pressure plate									
			22 22 A 125 Vac/250 Vac		H RAST-5 250# connector					04 Simulated roller lever			
			26 0.02 A 250 Vac 26 A 250 Vac		K Slot hole, solder terminal					05 Roller lever			
					L Left side, PCB terminal					06 Long roller lever			
					M Short sholder terminal					** Special			
					N RAST-7 250# connector								
					P Straight PCB terminal								
				R Right side, PCB terminal									
				S Solder terminal									
				T Screw terminal									
				** Special terminal									

^a "H" temperature grade not allowed with "26" electrical rating
¹ "100" gf not allowed with "26" electrical rating
** Additional code assigned for specials

MICRO SWITCH™ Standard Basic Switches, V15 Series

PRODUCT SPECIFICATIONS AND LISTINGS

Contact your Honeywell rep or distributor for additional listings

O.F. • Operating force O.T. • Overtravel
 R.F. • Release force D.T. • Differential travel
 P.T. • Pretravel O.P. • Operating position

Catalog Listing	Elec. Rating UL/cUL (ENEC)	Electrical Rating (see page 5)	Temperature Rating	Circuitry	O.F. max. g [oz]	R. F. max. g [oz]	O.P. nominal mm [in]	P.T. max. mm [in]	D.T. min. mm [in]	O.T. max. mm [in]	Mounting holes
V15S05-CP100	5 A (5 A)	05	85 °C	SPNO	100 [3.53]	25 [0.88]	14,7 [0.58]	1,6 [0.06]	0,4 [0.02]	0,8 [0.03]	Metric
V15S05-CZ015	5 A (5 A)	05	85 °C	SPDT	15 [0.53]	3 [0.11]	14,7 [0.58]	1,6 [0.06]	0,4 [0.02]	0,8 [0.03]	Metric
V15S05-CZ100	5 A (5 A)	05	85 °C	SPDT	100 [3.53]	25 [0.88]	14,7 [0.58]	1,6 [0.06]	0,4 [0.02]	0,8 [0.03]	Metric
V15S05-EZ100-K	5 A (5 A)	05	85 °C	SPDT	100 [3.53]	25 [0.88]	14,7 [0.58]	1,6 [0.06]	0,4 [0.02]	0,8 [0.03]	USA
V15H10-CP100	10 A (---)	H10	150 °C	SPNO	100 [3.53]	25 [0.88]	14,7 [0.58]	1,6 [0.06]	0,4 [0.02]	0,8 [0.03]	Metric
V15H10-CZ100	10 A (---)	H10	150 °C	SPDT	100 [3.53]	25 [0.88]	14,7 [0.58]	1,6 [0.06]	0,4 [0.02]	0,8 [0.03]	Metric
V15H10-EZ100	10 A (---)	H10	150 °C	SPDT	100 [3.53]	25 [0.88]	14,7 [0.58]	1,6 [0.06]	0,4 [0.02]	0,8 [0.03]	Metric
V15T10-CZ100	11 A (10 A)	T10	125 °C	SPDT	100 [3.53]	25 [0.88]	14,7 [0.58]	1,6 [0.06]	0,4 [0.02]	0,8 [0.03]	Metric
V15T16-CP100	16 A (16 A)	16	125 °C	SPNO	100 [3.53]	25 [0.88]	14,7 [0.58]	1,6 [0.06]	0,4 [0.02]	0,8 [0.03]	Metric
V15T16-CZ100-K	16 A (16 A)	16	125 °C	SPDT	100 [3.53]	25 [0.88]	14,7 [0.58]	1,6 [0.06]	0,4 [0.02]	0,8 [0.03]	USA
V15T16-EZ100-K	16 A (16 A)	16	125 °C	SPDT	100 [3.53]	25 [0.88]	14,7 [0.58]	1,6 [0.06]	0,4 [0.02]	0,8 [0.03]	USA
V15H16-CZ100	16 A (16 A)	16	150 °C	SPDT	100 [3.53]	25 [0.88]	14,7 [0.58]	1,6 [0.06]	0,4 [0.02]	0,8 [0.03]	Metric
V15H16-EZ100	16 A (16 A)	16	150 °C	SPDT	100 [3.53]	25 [0.88]	14,7 [0.58]	1,6 [0.06]	0,4 [0.02]	0,8 [0.03]	Metric
V15T22-CP100-K	22 A (22 A)	22	125 °C	SPNO	100 [3.53]	25 [0.88]	14,7 [0.58]	1,6 [0.06]	0,4 [0.02]	0,8 [0.03]	USA
V15T22-CZ100-K	22 A (22 A)	22	125 °C	SPDT	100 [3.53]	25 [0.88]	14,7 [0.58]	1,6 [0.06]	0,4 [0.02]	0,8 [0.03]	USA
V15H22-CP100	22 A (22 A)	22	150 °C	SPNO	100 [3.53]	25 [0.88]	14,7 [0.58]	1,6 [0.06]	0,4 [0.02]	0,8 [0.03]	Metric
V15H22-CZ100	22 A (22 A)	22	150 °C	SPDT	100 [3.53]	25 [0.88]	14,7 [0.58]	1,6 [0.06]	0,4 [0.02]	0,8 [0.03]	Metric
V15T26-CP200-K	--- (26 A)	26	125 °C	SPNO	200 [7.05]	50 [1.76]	14,7 [0.58]	1,6 [0.06]	0,4 [0.02]	0,8 [0.03]	USA
V15T26-CZ200	--- (26 A)	26	125 °C	SPDT	200 [7.05]	50 [1.76]	14,7 [0.58]	1,6 [0.06]	0,4 [0.02]	0,8 [0.03]	Metric





Pin Plunger

MICRO SWITCH™ Standard Basic Switches, V15 Series

PRODUCT SPECIFICATIONS AND LISTINGS

Contact your Honeywell rep or distributor for additional listings

O.F. • Operating force O.T. • Overtravel
 R.F. • Release force D.T. • Differential travel
 P.T. • Pretravel O.P. • Operating position



	Catalog Listing	Elec. Rating UL/cUL (ENEC)	Electrical Rating (see page 5)	Temperature Rating	Circuitry	O.F. max. g [oz]	R. F. max. g [oz]	O.P. nominal mm [in]	P.T. max. mm [in]	D.T. min. mm [in]	O.T. max. mm [in]	Mounting holes
 <p>Short Straight Lever</p>	V15H10-EZ200B01	10 A (---)	H10	150 °C	SPDT	140 [4.94]	20 [0.71]	15,3 [0.60]	2,4 [0.09]	0,6 [0.023]	1,2 [0.05]	Metric
	V15T10-CZ100A01	11 A (10 A)	T10	125 °C	SPDT	100 [3.53]	25 [0.88]	15,3 [0.60]	1,6 [0.06]	0,4 [0.02]	0,8 [0.03]	Metric
	V15H16-EZ100A01	16 A (16 A)	16	150 °C	SPDT	100 [3.53]	25 [0.88]	15,3 [0.60]	1,6 [0.06]	0,4 [0.02]	0,8 [0.03]	Metric
	V15H16-EZ400A01	16 A (16 A)	16	150 °C	SPDT	400 [14.11]	100 [3.53]	15,3 [0.60]	1,6 [0.06]	0,4 [0.02]	0,8 [0.03]	Metric
	V15T16-CC100A01	16 A (16 A)	16	125 °C	SPNC	100 [3.53]	25 [0.88]	15,3 [0.60]	1,6 [0.06]	0,4 [0.02]	0,8 [0.03]	Metric
	V15T16-CP300A01	16 A (16 A)	16	125 °C	SPNO	300 [10.58]	75 [2.65]	15,3 [0.60]	1,6 [0.06]	0,4 [0.02]	0,8 [0.03]	Metric
	V15T16-E1Z100A01-K	16 A (16 A)	16	125 °C	SPDT	100 [3.53]	25 [0.88]	15,3 [0.60]	1,6 [0.06]	0,4 [0.02]	0,8 [0.03]	USA
	V15T16-EP200A01	16 A (16 A)	16	125 °C	SPNO	200 [7.05]	50 [1.76]	15,3 [0.60]	1,6 [0.06]	0,4 [0.02]	0,8 [0.03]	Metric
	V15T16-EZ200A01-K	16 A (16 A)	16	125 °C	SPDT	200 [7.05]	50 [1.76]	15,3 [0.60]	1,6 [0.06]	0,4 [0.02]	0,8 [0.03]	USA
 <p>Standard Straight Lever</p>	V15S05-CZ025B02	5 A (5 A)	05	85 °C	SPDT	10 [0.35]	2 [0.07]	15,3 [0.60]	6,0 [0.24]	1,65 [0.064]	2,2 [0.086]	Metric
	V15S05-EZ025A02	5 A (5 A)	05	85 °C	SPDT	15 [0.53]	2 [0.07]	15,3 [0.60]	3,2 [0.126]	1,2 [0.047]	1,3 [0.051]	Metric
	V15H10-CC200A02	10 A (---)	H10	150 °C	SPNC	120 [4.23]	20 [0.71]	15,3 [0.60]	3,2 [0.126]	1,2 [0.047]	1,3 [0.051]	Metric
	V15T10-CZ050A02	11 A (10 A)	T10	125 °C	SPDT	30 [1.06]	5 [0.18]	15,3 [0.60]	3,2 [0.126]	1,2 [0.047]	1,3 [0.051]	Metric
	V15H16-CP100A02	16 A (16 A)	16	150 °C	SPNO	60 [2.12]	10 [0.35]	15,3 [0.60]	3,2 [0.126]	1,2 [0.047]	1,3 [0.051]	Metric
	V15H16-CZ100A02	16 A (16 A)	16	150 °C	SPDT	60 [2.12]	10 [0.35]	15,3 [0.60]	3,2 [0.126]	1,2 [0.047]	1,3 [0.051]	Metric
	V15H16-CZ200A02	16 A (16 A)	16	150 °C	SPDT	120 [4.23]	20 [0.71]	15,3 [0.60]	3,2 [0.126]	1,2 [0.047]	1,3 [0.051]	Metric
	V15H16-EP400A02-K	16 A (16 A)	16	150 °C	SPNO	240 [8.47]	40 [1.41]	15,3 [0.60]	3,2 [0.126]	1,2 [0.047]	1,3 [0.051]	USA
	V15H16-EZ200B02	16 A (16 A)	16	150 °C	SPDT	80 [2.82]	16 [0.56]	15,3 [0.60]	6,0 [0.24]	1,65 [0.064]	2,2 [0.09]	Metric
	V15T16-CP300A02	16 A (16 A)	16	125 °C	SPNO	180 [6.35]	30 [1.06]	15,3 [0.60]	3,2 [0.126]	1,2 [0.047]	1,3 [0.051]	Metric
	V15T16-CZ100A02	16 A (16 A)	16	125 °C	SPDT	60 [2.12]	10 [0.35]	15,3 [0.60]	3,2 [0.126]	1,2 [0.047]	1,3 [0.051]	Metric
	V15T16-DZ100A02	16 A (16 A)	16	125 °C	SPDT	60 [2.12]	10 [0.35]	15,3 [0.60]	3,2 [0.126]	1,2 [0.047]	1,3 [0.051]	Metric
	V15T16-MZ200A02	16 A (16 A)	16	125 °C	SPDT	120 [4.23]	20 [0.71]	15,3 [0.60]	3,2 [0.126]	1,2 [0.047]	1,3 [0.051]	Metric
	V15T22-CZ300A02	22 A (22 A)	22	125 °C	SPDT	180 [6.35]	30 [1.06]	15,3 [0.60]	3,2 [0.126]	1,2 [0.047]	1,3 [0.051]	Metric
	V15H22-CP100A02	22 A (22 A)	22	150 °C	SPNO	60 [2.12]	10 [0.35]	15,3 [0.60]	3,2 [0.126]	1,2 [0.047]	1,3 [0.051]	Metric
	V15H22-CZ100A02	22 A (22 A)	22	150 °C	SPDT	60 [2.12]	10 [0.35]	15,3 [0.60]	3,2 [0.126]	1,2 [0.047]	1,3 [0.051]	Metric
V15T22-KC200A02	22 A (22 A)	22	125 °C	SPNC	120 [4.23]	20 [0.71]	15,3 [0.60]	3,2 [0.126]	1,2 [0.047]	1,3 [0.051]	Metric	

MICRO SWITCH™ Standard Basic Switches, V15 Series

PRODUCT SPECIFICATIONS AND LISTINGS

Contact your Honeywell rep or distributor for additional listings

O.F. • Operating force O.T. • Overtravel
 R.F. • Release force D.T. • Differential travel
 P.T. • Pretravel O.P. • Operating position

	Catalog Listing	Elec. Rating UL/cUL (ENEC)	Electrical Rating (see page 5)	Temperature Rating	Circuitry	O.F. max. g [oz]	R. F. max. g [oz]	O.P. nominal mm [in]	P.T. max. mm [in]	D.T. min. mm [in]	O.T. max. mm [in]	Mounting holes
 Long Straight Lever	V15H10-FP200A03	10 A (---)	H10	150 °C	SPNO	60 [2.12]	10 [0.35]	15,3 [0.60]	6,4 [0.25]	2,4 [0.09]	2,6 [0.10]	Metric
	V15T10-CZ200A03	11 A (10 A)	T10	125 °C	SPDT	60 [2.12]	10 [0.35]	15,3 [0.60]	6,4 [0.25]	2,4 [0.09]	2,6 [0.10]	Metric
	V15H16-CZ100A03-K	16 A (16 A)	16	150 °C	SPDT	30 [1.06]	5 [0.18]	15,3 [0.60]	6,4 [0.25]	2,4 [0.09]	2,6 [0.10]	USA
	V15H16-CZ300A03-K	16 A (16 A)	16	150 °C	SPDT	90 [3.17]	15 [0.53]	15,3 [0.60]	6,4 [0.25]	2,4 [0.09]	2,6 [0.10]	USA
	V15T16-CZ100A03	16 A (16 A)	16	125 °C	SPDT	30 [1.06]	5 [0.18]	15,3 [0.60]	6,4 [0.25]	2,4 [0.09]	2,6 [0.10]	Metric
	V15T16-DZ100A03	16 A (16 A)	16	125 °C	SPDT	30 [1.06]	5 [0.18]	15,3 [0.60]	6,4 [0.25]	2,4 [0.09]	2,6 [0.10]	Metric
	V15T16-EZ200A03-K	16 A (16 A)	16	125 °C	SPDT	60 [2.12]	10 [0.35]	15,3 [0.60]	6,4 [0.25]	2,4 [0.09]	2,6 [0.10]	USA
	V15H22-CP200B03	22 A (22 A)	22	150 °C	SPNO	32 [1.13]	8 [0.28]	15,3 [0.60]	12 [0.47]	3,5 [0.14]	5,3 [0.21]	Metric
	V15H22-CZ300A03-K	22 A (22 A)	22	150 °C	SPDT	90 [3.17]	15 [0.53]	15,3 [0.60]	6,4 [0.25]	2,4 [0.09]	2,6 [0.10]	USA
	V15T22-CZ100A03	22 A (22 A)	22	125 °C	SPDT	30 [1.06]	5 [0.18]	15,3 [0.60]	6,4 [0.25]	2,4 [0.09]	2,6 [0.10]	Metric
	V15T26-CZ200A03	--- (26 A)	26	125 °C	SPDT	60 [2.12]	10 [0.35]	15,3 [0.60]	6,4 [0.25]	2,4 [0.09]	2,6 [0.10]	Metric
 Simulated Roller	V15H16-CZ200B04	16A (16A)	16	150 °C	SPDT	80 [2.82]	15 [0.53]	18,5 [0.73]	6,0 [0.24]	1,65 [0.064]	2,2 [0.09]	Metric
	V15H16-CZ300A04	16A (16A)	16	150 °C	SPDT	180 [6.35]	30 [1.06]	18,5 [0.73]	3,2 [0.13]	1,2 [0.05]	1,3 [0.05]	Metric
	V15T16-CZ100A04	16A (16A)	16	125 °C	SPDT	60 [2.12]	10 [0.35]	18,5 [0.73]	3,2 [0.13]	1,2 [0.05]	1,3 [0.05]	Metric
	V15T16-DZ100A04	16A (16A)	16	125 °C	SPDT	60 [2.12]	10 [0.35]	18,5 [0.73]	3,2 [0.13]	1,2 [0.05]	1,3 [0.05]	Metric
	V15T16-EZ200A04-K	16A (16A)	16	125 °C	SPDT	120 [4.23]	20 [0.71]	18,5 [0.73]	3,2 [0.13]	1,2 [0.05]	1,3 [0.05]	USA
	V15H22-CZ200B04-K	22 A (22 A)	22	150 °C	SPDT	80 [2.82]	15 [0.53]	18,5 [0.73]	6,0 [0.24]	1,65 [0.064]	2,2 [0.09]	USA
	V15T22-CP200A04	22 A (22 A)	22	125 °C	SPNO	120 [4.23]	20 [0.71]	18,5 [0.73]	3,2 [0.13]	1,2 [0.05]	1,3 [0.05]	Metric
	V15T22-CZ300A04	22 A (22 A)	22	125 °C	SPDT	180 [6.35]	30 [1.06]	18,5 [0.73]	3,2 [0.13]	1,2 [0.05]	1,3 [0.05]	Metric
	V15T22-DC200A04	22 A (22 A)	22	125 °C	SPNC	120 [4.23]	20 [0.71]	18,5 [0.73]	3,2 [0.13]	1,2 [0.05]	1,3 [0.05]	Metric
	V15T22-TP200A04	22 A (22 A)	22	125 °C	SPNO	120 [4.23]	20 [0.71]	18,5 [0.73]	3,2 [0.13]	1,2 [0.05]	1,3 [0.05]	Metric
	V15T26-CZ300A04	--- (26 A)	26	125 °C	SPDT	180 [6.35]	30 [1.06]	18,5 [0.73]	3,2 [0.13]	1,2 [0.05]	1,3 [0.05]	Metric

MICRO SWITCH™ Standard Basic Switches, V15 Series

PRODUCT SPECIFICATIONS AND LISTINGS

Contact your Honeywell rep or distributor for additional listings

O.F. • Operating force O.T. • Overtravel
 R.F. • Release force D.T. • Differential travel
 P.T. • Pretravel O.P. • Operating position

Catalog Listing	Elec. Rating UL/cUL (ENEC)	Electrical Rating (see page 5)	Temperature Rating	Circuitry	O.F. max. g [oz]	R. F. max. g [oz]	O.P. nominal mm [in]	P.T. max. mm [in]	D.T. min. mm [in]	O.T. max. mm [in]	Mounting holes
V15S05-EZ050A05	5 A (5 A)	05	85 °C	SPDT	60 [2.12]	10 [0.35]	20,6 [0.81]	1,6 [0.06]	0,4 [0.02]	0,8 [0.03]	Metric
V15S05-EZ100A05	5 A (5 A)	05	85 °C	SPDT	120 [4.23]	20 [0.71]	20,6 [0.81]	1,6 [0.06]	0,4 [0.02]	0,8 [0.03]	Metric
V15T10-EZ200A05	11 A (10 A)	T10	125 °C	SPDT	240 [8.47]	40 [1.41]	20,6 [0.81]	1,6 [0.06]	0,4 [0.02]	0,8 [0.03]	Metric
V15H16-CZ100A05	16 A (16 A)	16	150 °C	SPDT	120 [4.23]	20 [0.71]	20,6 [0.81]	1,6 [0.06]	0,4 [0.02]	0,8 [0.03]	Metric
V15H16-EP100A05	16 A (16 A)	16	150 °C	SPNO	120 [4.23]	20 [0.71]	20,6 [0.81]	1,6 [0.06]	0,4 [0.02]	0,8 [0.03]	Metric
V15H16-EZ200A05	16 A (16 A)	16	150 °C	SPDT	240 [8.47]	40 [1.41]	20,6 [0.81]	1,6 [0.06]	0,4 [0.02]	0,8 [0.03]	Metric
V15T16-CC100A05	16 A (16 A)	16	125 °C	SPNC	120 [4.23]	20 [0.71]	20,6 [0.81]	1,6 [0.06]	0,4 [0.02]	0,8 [0.03]	Metric
V15T16-CZ100A05	16 A (16 A)	16	125 °C	SPDT	120 [4.23]	20 [0.71]	20,6 [0.81]	1,6 [0.06]	0,4 [0.02]	0,8 [0.03]	Metric
V15T16-DZ100A05	16 A (16 A)	16	125 °C	SPDT	120 [4.23]	20 [0.71]	20,6 [0.81]	1,6 [0.06]	0,4 [0.02]	0,8 [0.03]	Metric
V15T16-EZ2200A05	16 A (16 A)	16	125 °C	SPDT	240 [8.47]	40 [1.41]	20,6 [0.81]	1,6 [0.06]	0,4 [0.02]	0,8 [0.03]	Metric
V15T16-EP200A05	16 A (16 A)	16	125 °C	SPNO	240 [8.47]	40 [1.41]	20,6 [0.81]	1,6 [0.06]	0,4 [0.02]	0,8 [0.03]	Metric
V15T16-EZ100A05	16 A (16 A)	16	125 °C	SPDT	120 [4.23]	20 [0.71]	20,6 [0.81]	1,6 [0.06]	0,4 [0.02]	0,8 [0.03]	Metric
V15T16-MZ200A05	16 A (16 A)	16	125 °C	SPDT	240 [8.47]	40 [1.41]	20,6 [0.81]	1,6 [0.06]	0,4 [0.02]	0,8 [0.03]	Metric
V15H22-CZ100A05	22 A (22 A)	22	150 °C	SPDT	120 [4.23]	20 [0.71]	20,6 [0.81]	1,6 [0.06]	0,4 [0.02]	0,8 [0.03]	Metric
V15T22-CZ200A05	22 A (22 A)	22	125 °C	SPDT	240 [8.47]	40 [1.41]	20,6 [0.81]	1,6 [0.06]	0,4 [0.02]	0,8 [0.03]	Metric



Short Roller Lever

MICRO SWITCH™ Standard Basic Switches, V15 Series

PRODUCT SPECIFICATIONS AND LISTINGS

Contact your Honeywell rep or distributor for additional listings

O.F. • Operating force O.T. • Overtravel
 R.F. • Release force D.T. • Differential travel
 P.T. • Pretravel O.P. • Operating position

	Catalog Listing	Elec. Rating UL/cUL (ENEC)	Electrical Rating (see page 5)	Temperature Rating	Circuitry	O.F. max. g [oz]	R. F. max. g [oz]	O.P. nominal mm [in]	P.T. max. mm [in]	D.T. min. mm [in]	O.T. max. mm [in]	Mounting holes
 <p>Roller Lever</p>	V15S05-CP200A06	5 A (5 A)	05	85 °C	SPNO	120 [4.23]	20 [0.71]	20,6 [0.81]	3,2 [0.13]	1,2 [0.05]	1,3 [0.05]	Metric
	V15S05-EZ050A06	5 A (5 A)	05	85 °C	SPDT	35 [1.23]	5 [0.18]	20,6 [0.81]	3,2 [0.13]	1,2 [0.05]	1,3 [0.05]	Metric
	V15T10-EZ200A06	11 A (10 A)	T10	125 °C	SPDT	120 [4.23]	20 [0.71]	20,6 [0.81]	3,2 [0.13]	1,2 [0.05]	1,3 [0.05]	Metric
	V15H16-CZ100A06-K	16 A (16 A)	16	150 °C	SPDT	60 [2.12]	10 [0.35]	20,6 [0.81]	3,2 [0.13]	1,2 [0.05]	1,3 [0.05]	USA
	V15H16-EP200B06	16 A (16 A)	16	150 °C	SPNO	80 [2.82]	10 [0.35]	20,6 [0.81]	6,0 [0.24]	1,6 [0.06]	2,2 [0.09]	Metric
	V15T16-CP200A06	16 A (16 A)	16	125 °C	SPNO	120 [4.23]	20 [0.71]	20,6 [0.81]	3,2 [0.13]	1,2 [0.05]	1,3 [0.05]	Metric
	V15T16-CZ100A06	16 A (16 A)	16	125 °C	SPDT	60 [2.12]	10 [0.35]	20,6 [0.81]	3,2 [0.13]	1,2 [0.05]	1,3 [0.05]	Metric
	V15T16-DZ100A06	16 A (16 A)	16	125 °C	SPDT	60 [2.12]	10 [0.35]	20,6 [0.81]	3,2 [0.13]	1,2 [0.05]	1,3 [0.05]	Metric
	V15T16-EZ100A06	16 A (16 A)	16	125 °C	SPDT	60 [2.12]	10 [0.35]	20,6 [0.81]	3,2 [0.13]	1,2 [0.05]	1,3 [0.05]	Metric
	V15T16-MZ200A06	16 A (16 A)	16	125 °C	SPDT	120 [4.23]	20 [0.71]	20,6 [0.81]	3,2 [0.13]	1,2 [0.05]	1,3 [0.05]	Metric
	V15H22-CZ100A06	22 A (22 A)	22	150 °C	SPDT	60 [2.12]	10 [0.35]	20,6 [0.81]	3,2 [0.13]	1,2 [0.05]	1,3 [0.05]	Metric
	V15T22-CZ200A06	22 A (22 A)	22	125 °C	SPDT	120 [4.23]	20 [0.71]	20,6 [0.81]	3,2 [0.13]	1,2 [0.05]	1,3 [0.05]	Metric

MICRO SWITCH™ Standard Basic Switches, V15 Series

MOUNTING DIMENSIONS

Figure 1. V15 Series Standard Switch Dimensions

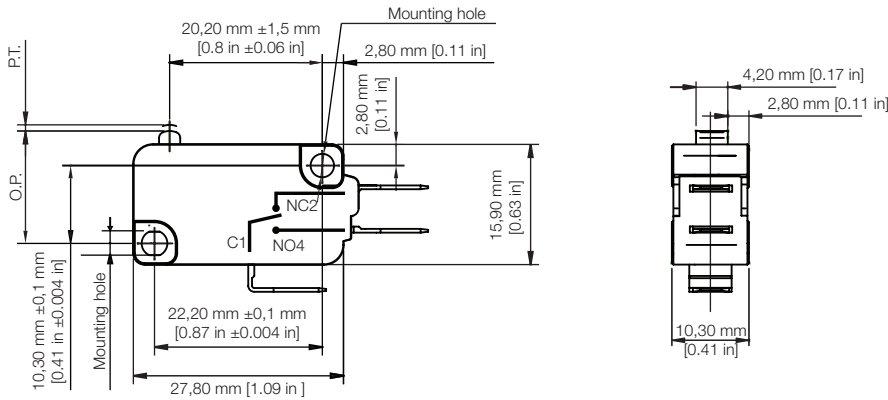

Figure 2. V15 Series Metric Mounting Hole Dimensions for Ø 3 mm pins or screws

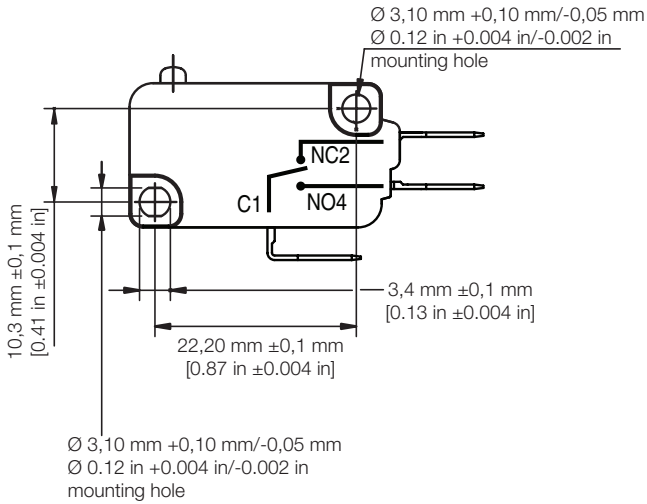

Figure 3. V15 Series USA Mounting Hole Dimensions for #4 screws

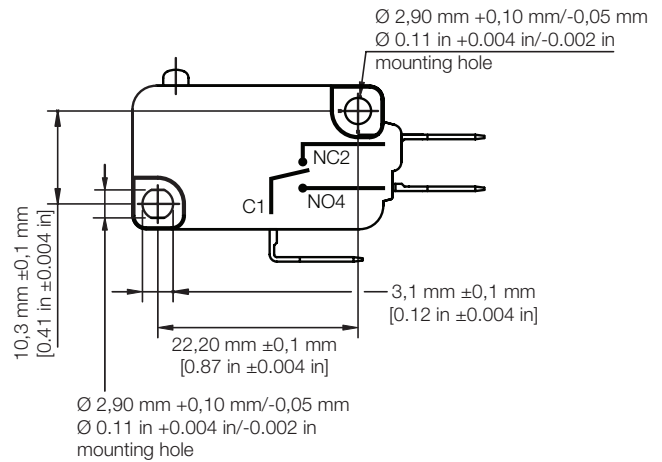

Figure 4. V15 Series Housing Dimensions

Basic Housing Type	Flat Housing Type	Fully Flat Housing Type
<p>1,9 mm [0.075 in]</p>	<p>1,0 mm [0.039 in]</p>	<p>1,0 mm [0.039 in]</p>

MICRO SWITCH™ Standard Basic Switches, V15 Series

CONNECTION DIMENSIONS

Figure 5. V15 Series C-style Quick Connect • 6,35 mm wide x 0,8 mm thick
[0.25 in wide x 0.031 in thick]

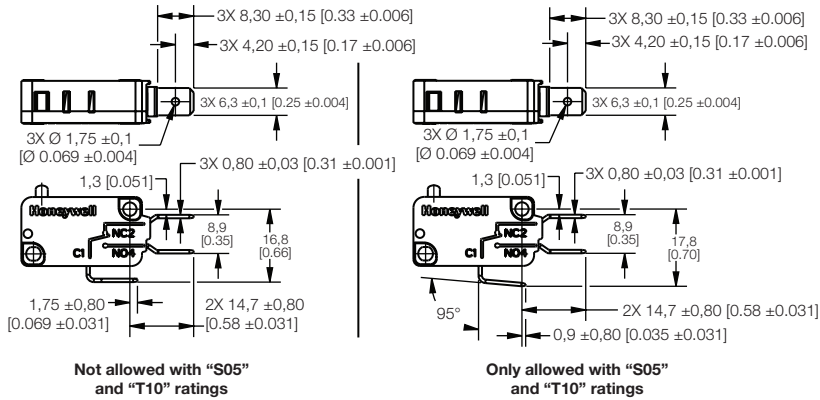

Figure 6. V15 Series H-style RAST-5 250# Connector

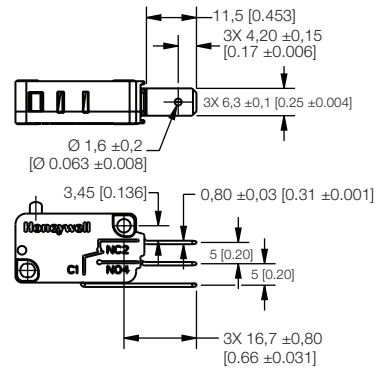

Figure 7. V15 Series D-style Quick Connect • 4,80 mm wide x 0,8 mm thick
[0.189 in wide x 0.031 in thick]

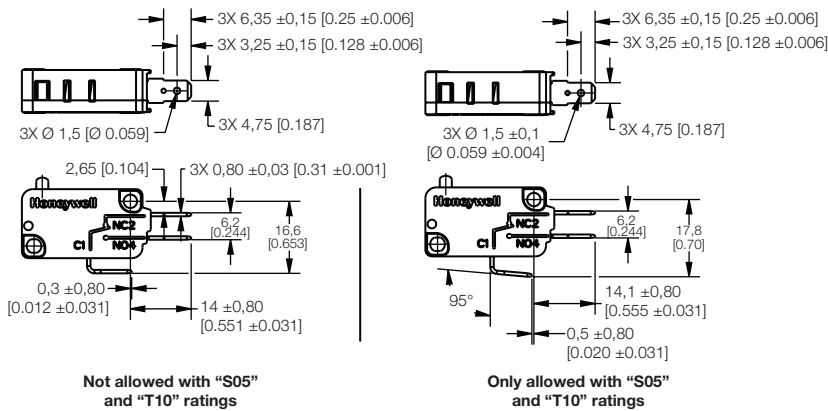

Figure 8. V15 Series N-style RAST-7 250# Connector

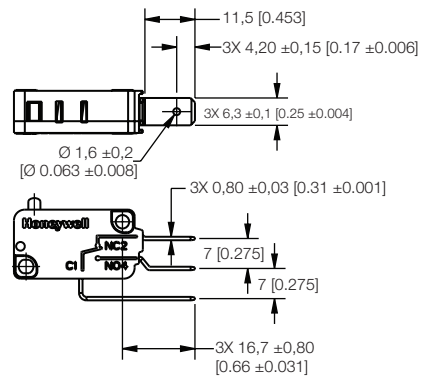

Figure 9. V15 Series E-style Quick Connect • 4,80 mm wide x 0,5 mm thick
[0.189 in wide x 0.020 in thick]

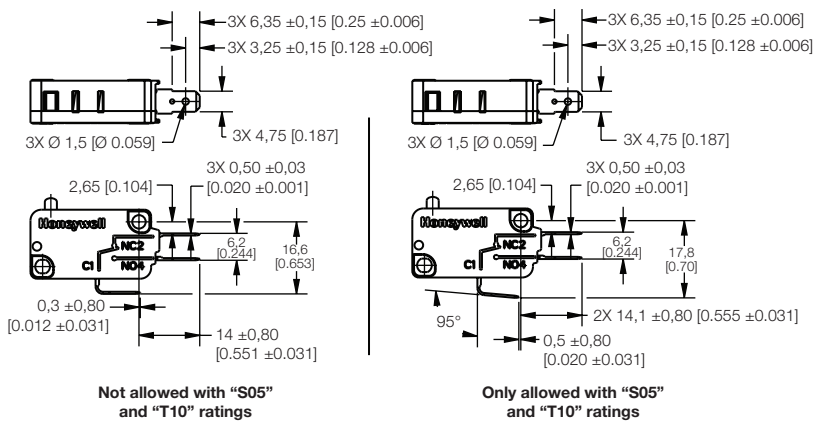
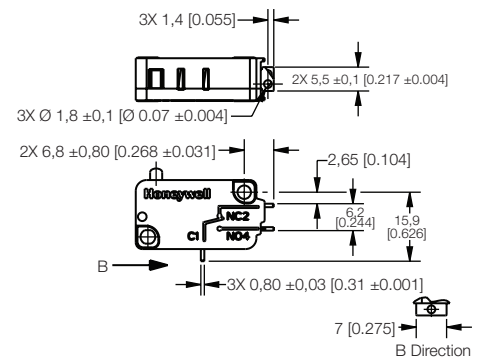

Figure 10. V15 Series M-style Short Solder Terminal



MICRO SWITCH™ Standard Basic Switches, V15 Series

CONNECTION DIMENSIONS

Figure 11. V15 Series K-style Slot-Hole Solder Terminal

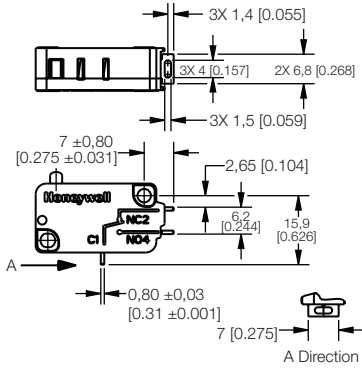

Figure 12. V15 Series S-style Solder Terminal

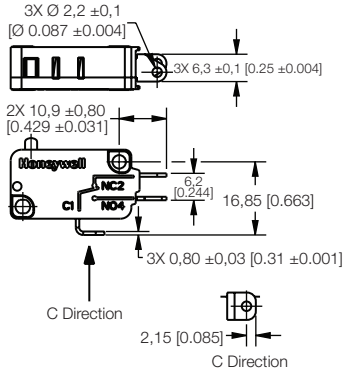

Figure 13. V15 Series T-style Screw Terminal

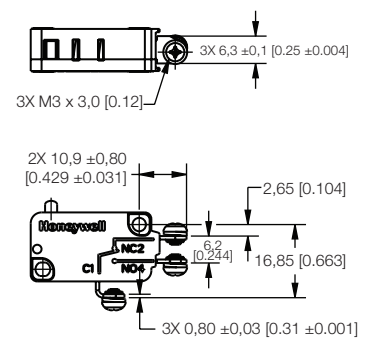

Figure 14. V15 Series L-style Left-Side PCB Terminal

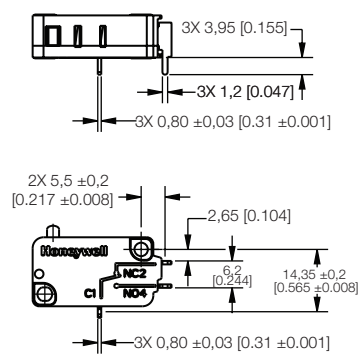

Figure 15. V15 Series P-style Straight PCB Terminal

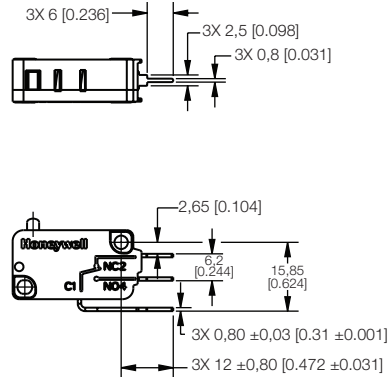

Figure 16. V15 Series R-style Right-Side PCB Terminal

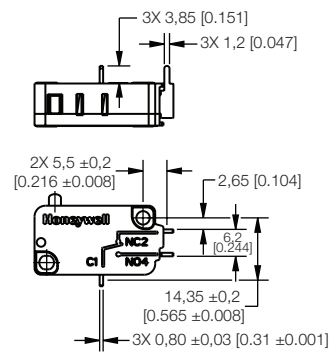

Figure 17. V15 Series F-style Screw Terminal with Pressure Plate

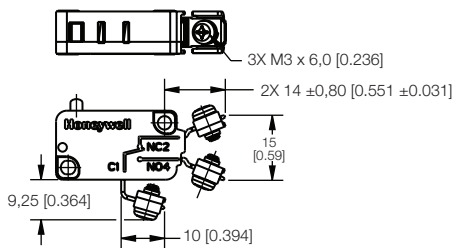
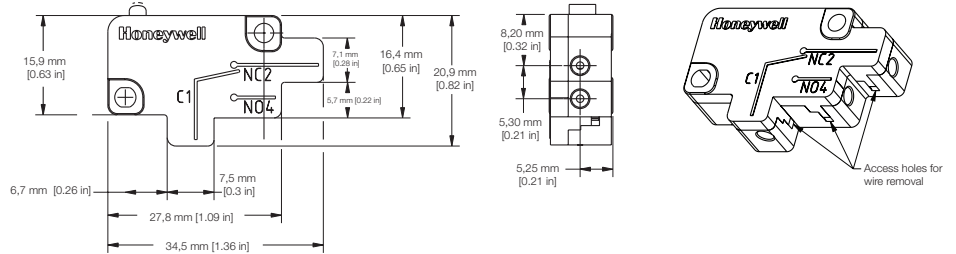

Figure 18. V15 Series U-Style Push-In Terminal (only allowed with V15S11)



MICRO SWITCH™ Standard Basic Switches, V15 Series

STANDARD LEVER OPTIONS • DIMENSIONS

Figure 19. V15 Series A01/Straight Short Lever

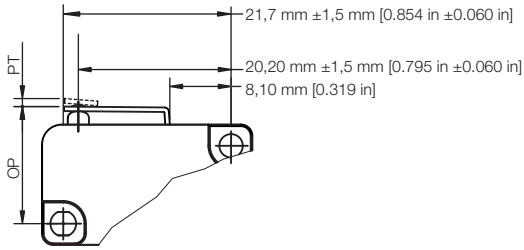

Figure 20. V15 Series A02/Standard Straight Lever

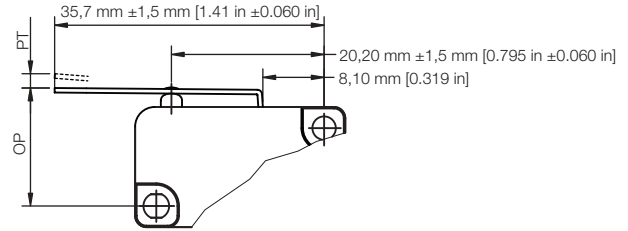

Figure 21. V15 Series A03/Long Straight Lever

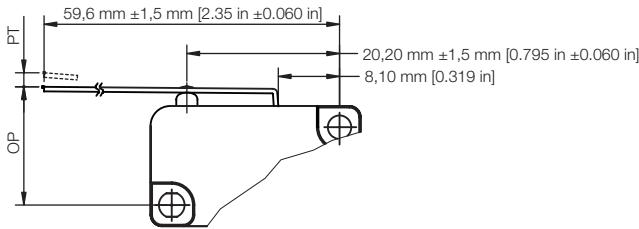

Figure 22. V15 Series A04/Simulated Roller Lever

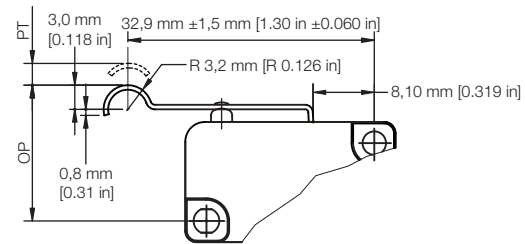

Figure 23. V15 Series A05/Short Roller Lever

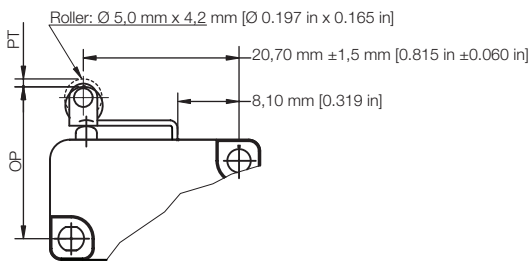
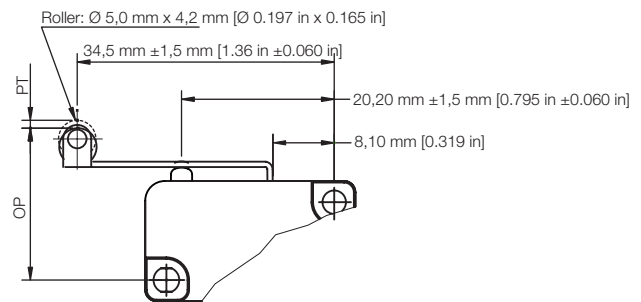
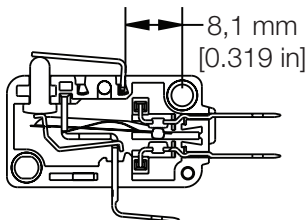

Figure 24. V15 Series A06/Roller Lever



NOTE: These dimensions apply for the "A" lever position. For the "B" lever position, please add 5,7 mm [0.224 in].

Position A



Position B

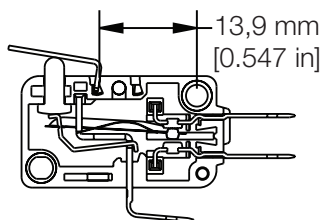

ADDITIONAL MATERIALS

The following associated literature is available on the Honeywell web site at sensing.honeywell.com:

- Installation instructions
- Product part listing/nomenclature tree
- Product application-specific information
 - Application note: Electronic sensors and electromechanical switches in valves and flow meters
 - Application note: Electronic sensors and MICRO SWITCH™ switches in industrial air compressors
 - Application note: Sensors and switches for potential HVAC/R applications
 - Application note: Sensors and switches for valve monitors and valve indicators
 - Application note: Sensors and switches in sanitary valves
 - Case study: Switching it up
 - Technical bulletin: Applying precision switches

Find out more

Honeywell serves its customers through a worldwide network of sales offices, representatives and distributors. For application assistance, current specifications, pricing or name of the nearest Authorized Distributor, contact your local sales office.

To learn more about Honeywell's sensing and control products, call **+1-815-235-6847** or **1-800-537-6945**, visit **sensing.honeywell.com**, or e-mail inquiries to **info.sc@honeywell.com**

Honeywell Sensing and Productivity Solutions

9680 Old Bailes Road
Fort Mill, SC 29707
honeywell.com

004945-8-EN IL50 GLO
April 2016
© 2016 Honeywell International Inc. All rights reserved.

WARNING **PERSONAL INJURY**

DO NOT USE these products as safety or emergency stop devices or in any other application where failure of the product could result in personal injury.

Failure to comply with these instructions could result in death or serious injury.

WARNING **MISUSE OF DOCUMENTATION**

- The information presented in this product sheet is for reference only. Do not use this document as a product installation guide.
- Complete installation, operation, and maintenance information is provided in the instructions supplied with each product.

Failure to comply with these instructions could result in death or serious injury.

Warranty/Remedy

Honeywell warrants goods of its manufacture as being free of defective materials and faulty workmanship. Honeywell's standard product warranty applies unless agreed to otherwise by Honeywell in writing; please refer to your order acknowledgement or consult your local sales office for specific warranty details. If warranted goods are returned to Honeywell during the period of coverage, Honeywell will repair or replace, at its option, without charge those items it finds defective. **The foregoing is buyer's sole remedy and is in lieu of all other warranties, expressed or implied, including those of merchantability and fitness for a particular purpose. In no event shall Honeywell be liable for consequential, special, or indirect damages.**

While we provide application assistance personally, through our literature and the Honeywell web site, it is up to the customer to determine the suitability of the product in the application.

Specifications may change without notice. The information we supply is believed to be accurate and reliable as of this printing. However, we assume no responsibility for its use.

Honeywell

Mouser Electronics

Authorized Distributor

Click to View Pricing, Inventory, Delivery & Lifecycle Information:

Honeywell:

[V15T16-CZ100-K](#) [V15T16-CZ300-K](#) [V15T26-CZ300-K](#) [V15T16-CZ200](#) [V15T16-CZ400A02](#) [V15T16-CZ300A02](#)
[V15T16-CZ300A05](#) [V15T16-CC200](#) [V15H16-EZ200A05](#) [V15T22-CC300](#) [V15T16-EZ200A04](#) [V15T16-CZ200A04](#)
[V15T16-EZ200B02-K](#) [V15T16-EZ300A01](#) [V15T16-EZ300A04](#) [V15T22-DZ100B02](#) [V15T22-CZ200A05](#)