

# RVC7900 Series

## Modulating Control Valves

### SPECIFICATION DATA



## General

The RVC7900 Series Modulating Control Valves provide precision flow control of hot or chilled water in various heating and cooling applications.

The RVC hydronic valve consists of a valve body and replaceable characterized cartridge assembly. When used with a Resideo RVC7900 actuator, the valve provides proportional flow in modulating, diverting or mixing applications. They are designed to provide sinusoidal valve actuator travel, and therefore operate silently and resist water hammer.

The RVC7900 series valve actuator is used with any 0-10 Vdc or 2-10Vdc controller.

## Specifications

<b>Supply Voltage</b>	24Vac, 50/60Hz, Class 2 circuit
<b>Label color code</b>	Blue
<b>Control Signal</b>	
Input voltage	0/2 to 10 Vdc (actual 2 to 9 Vdc )
Input impedance	47.5kΩ
<b>Power Consumption</b>	Max. 4Watts (during valve position change)

*Note: Use 24V Class 2 transformer and provide 6 VA for connection wire sizing.*

<b>Maximum duty cycle</b>	15%
<b>Nominal Timing</b>	opens in 120 sec. @ 60 Hz Actual full stroke timing is 140 sec

*Note: Timing is approximately 20% longer @ 50 Hz*

<b>Electrical Termination</b>	With integral 1 meter (nominal 39") leadwire cable
-------------------------------	--

<b>Temperature</b>	
Ambient Operating	0 to 65 °C (32 to 150 °F)
Ambient Storage	-40 to +65 °C (-40 to 150 °F)
<b>Atmosphere</b>	Non-condensing, Non-corrosive, Non-explosive

<b>Fluid temperatures</b>	1 to 95 °C (34 to 203°F)
<b>Pressure Differential</b>	Max. 4 bar (60 psi)
<b>Pressure Rating:</b>	Static: 20 bar (300 psi) Burst: 100 bar (1500 psi)

<b>Valve Material</b>	
Body	Bronze
Cartridge	Ryton™ and Noryl™
O-ring seal	EPDM rubber
Stem	Stainless steel
<b>Stem Travel:</b>	10 mm (0.4 inches)
<b>Flow Characteristics:</b>	Linear

**Table 1. Selection**

OS#	Size(in.)	Size	2/3 Way	Cv
RVC7931AF1111T	1/2	DN15	2	3.4
RVC7931AJ1111T	3/4	DN20	2	5.7
RVC7931AP1111T	1	DN25	2	6
RVC7931ME6111T	1/2	DN15	3	3
RVC7931MH6111T	3/4	DN20	3	5.6
RVC7931MP6111T	1	DN25	3	6.9

1. The End Connection is BSPP, internal thread.
2. The Control Signal is Modulating.
3. The Electrical Termination is 1 meter cable.

**Table 2.2-Way Nominal Dimensions (See Fig. 3)**

Dimensions Pipe fitting sizes	C		D	
	mm	Inches	mm	Inches
DN15	98	3-7/8	111	4-3/8
DN20	94	3-11/16	113	4-7/16
DN25	94	3-11/16	113	4-7/16

**Table 3. 3-Way Nominal Dimensions (See Fig. 4)**

Dimensions Pipe fitting sizes	C		D	
	mm	Inches	mm	Inches
DN15	98	3-7/8	136	5-11/32
DN20	94	3-11/16	130	5-3/32
DN25	94	3-11/16	136	5-11/32

**Fig. 1 - Fluid flow of 2-way valves**

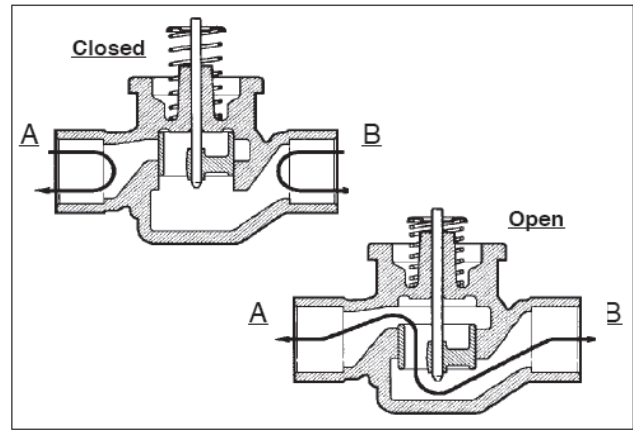

**Fig. 2 - Fluid flow of 3-way valves**

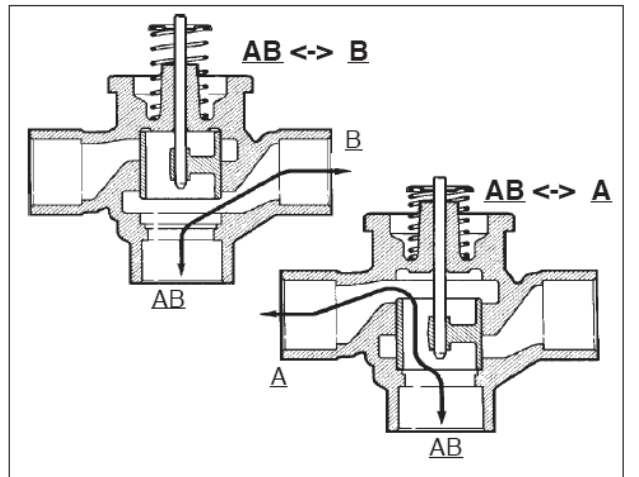

**Fig. 3 - 2-Way nominal dimensions in inches and millimetres**

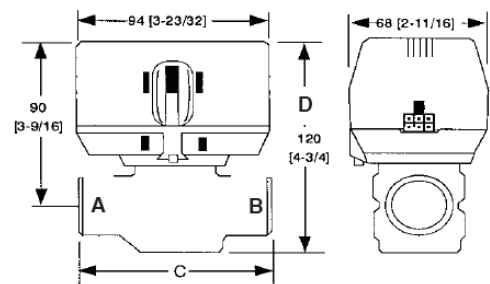
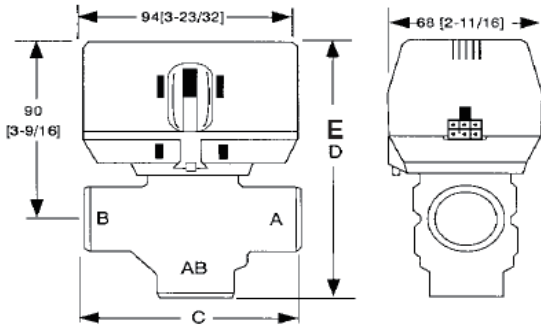

Fig.4 - 3-way nominal dimensions in inches and millimetres



## INSTALLATION

### WHEN INSTALLING THIS PRODUCT:

1. Read these instructions carefully. Failure to follow them could damage the product or cause a hazardous condition.
2. Check the ratings given in the instructions and on the product to make sure the product is suitable for your application.
3. Installer must be a trained, experienced service-person.
4. Always conduct a thorough check-out when installation is completed.
5. While not necessary to remove the actuator from the body, it can be removed for ease of installation. The actuator can be installed in any of the four orientations to suit the most convenient wiring direction. Actuator latching mechanism works only when the lengths of the actuator and the valve body are parallel to each other.
6. An extra 25 mm head clearance is required to remove the actuator.



#### CAUTION

1. Disconnect power supply before connecting wiring to prevent electrical shock and equipment damage.
2. Never jumper the supply wires or actuator terminals even temporarily. This may damage the thermostat.

## PLUMBING

The valve may be plumbed in any angle but preferably not with the actuator below horizontal level of the body. Make sure there is enough room around the actuator for servicing or replacement. For use in diverting applications, the valve is installed with the flow water entering through bottom port AB, and diverting through end ports A or B. In mixing applications the valve is installed with inlet to A or B and outlet through AB.

Mount the valve directly in the tube or pipe. Do not grip the actuator while making and tightening up plumbing connections. Either hold valve body in your hand or attach adjustable spanner (38 mm or 1-1/2") across hexagonal or flat faces on the valve body. (Figure 5)

Fig. 5 - Plumbing the VC Valve

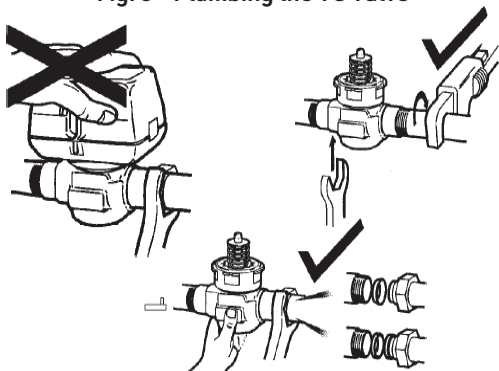

## TO INSTALL REPLACEMENT ACTUATOR IMPORTANT

Installation of a new actuator does not require draining the system, provided the valve body and valve cartridge assembly remain in the pipeline.

1. Check replacement part number and voltage ratings for match with old device.
2. Disconnect power supply before servicing to avoid electrical shock or equipment damage.
3. Disconnect leadwires to actuator. Where appropriate, label wires for rewiring.
4. The actuator head is automatically latched to the valve. To remove, press up on the latch mechanism with your thumb. It is located directly below the white manual open lever (see figure 6 below). Simultaneously press the actuator down towards the body with moderate hand force and turn the actuator counter-clockwise by 1/8 turn (45 degrees). Lift the actuator off the valve body.

*Note: The actuator can also be installed at right angles to the valve body but in this position the latch mechanism will not engage.*

5. Install the new actuator by reversing the process in (4).
6. Reconnect leadwires.
7. Restore power, and check-out operation.

Fig.6-Latch Mechanism to detach Actuator

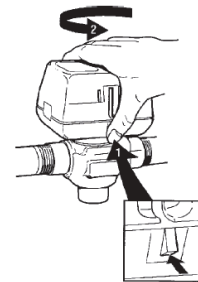

## MANUAL OPENERE

The manual opener can be manipulated only when in the up position. The "A" port can be manually opened by firmly pushing the white manual lever down to midway and in. In this position both the "A" and "B" ports are open, and with auxiliary switch models the switch is closed. This "manual open" position may be used for filling, venting and draining the system, or for opening the valve in case of power failure. The valve can be restored manually to the closed position by depressing the white manual lever lightly and then pulling the lever out. The valve and actuator will return to the automatic position when power is restored.

*Note: If the valve is powered open, it cannot be manually closed, unless actuator is removed.*

## WIRING

See figure 7 for single unit wiring details.

Multiple valves may be connected in parallel to a single controller and transformer, up to the current rating of the controller and transformer.

**Fig.7 - Wiring Colour Code for Cable Models for 0-10 Vdc Controller (Series 70).**

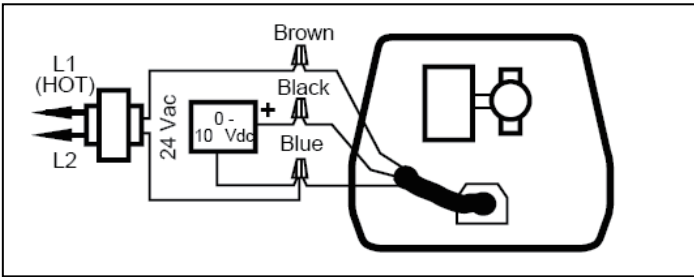

## SERVICE

This valve should be serviced by a trained, experienced service technician.

1. If the valve is leaking, drain system OR isolate valve from the system. Do not remove valve body from plumbing.
2. Check to see if the cartridge needs to be replaced.
3. If the motor or other internal parts of the actuator is damaged, replace the entire actuator assembly.

*Note: Honeywell hydronic valves are designed and tested for silent operation in properly designed and installed systems. However, water noises may occur as a result of excessive water velocity. Piping noises may also occur in high temperature (over 212°F [100 °C]) systems with insufficient water pressure.*

## OPERATION

### WITH SERIES 70, 0/2-10 VDC CONTROLLER

(refer to figure 8)

In the VC7900, an electronic circuit compares the voltage of the feedback potentiometer to the signal voltage. If they are different, then the circuit closes the appropriate triac and drives the motor in the direction that will bring the circuit back into balance. In addition, the standard limit switches maintain the travel to the normal operating range. In a direct acting model, 2V signal will be fully closed, and 9V will be fully open. In a reverse acting model, 9 V is closed and 2V is open. However, because of the soft close off of the VC valve, initial (and final) movements of the actuator will not cause any significant changes in the valve stem position. On a loss of power, the actuator will remain in the last position, and will resume normal operation on power up. On loss of signal, a direct acting device will go to the closed default position. A reverse acting device will default open.

## IMPORTANT

Do not use boiler additives which are petroleum based or contain mineral oil, hydrocarbons, or ethylene glycol acetate. Compounds which can be used, with minimum 50% water dilution, are diethylene glycol, ethylene glycol and propylene glycol (anti-freeze solutions)

## CHECK-OUT

1. Raise the set point of the thermostat above room temperature to initiate a call for heat.
2. Observe all control devices - 2 way valve should open. Port A in 3 way valve should open, and port B should close.
3. Lower the set point of the thermostat below room temperature.
4. Observe the control devices. 2 way valve should close. Port A in 3 way valve should close, and port B should open.

**Fig.8-Wiring Schematic of the RVC7900 Series Actuators**

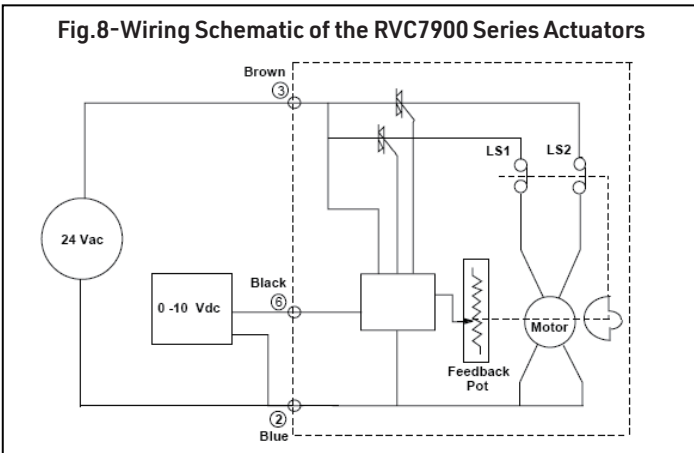

**Resideo Singapore Pte.Ltd**  
#04-01, 1 Paya Lebar Link

Paya Lebar Quarter 1  
Singapore 408533

Subject to change without notice.