

# Y-TYPE STRAINER (FLANGED) PN16

## SALIENT FEATURES

- Cast Iron Body with Powdercoating
- Flange end : IS 1538 / ISO7005-2 Standard
- Non Corrosionable SS304 perforated Sheet Screen
- Fine finish and Smooth Contour to minimize pressure drop inside the strainer
- Large Screening area makes the strainer highly efficient in performance



## SPECIFICATIONS

Size Range	DN20-DN350
Body	Cast Iron
Mesh	Stainless Steel (SS304)
Nominal pressure	PN 16
Test Pressure	Shell Test : 24 bar
Medium	Chilled and hotwater
Medium Temp.	-10°C to120°C
End Connection	(ISO7005-2)/IS 1538

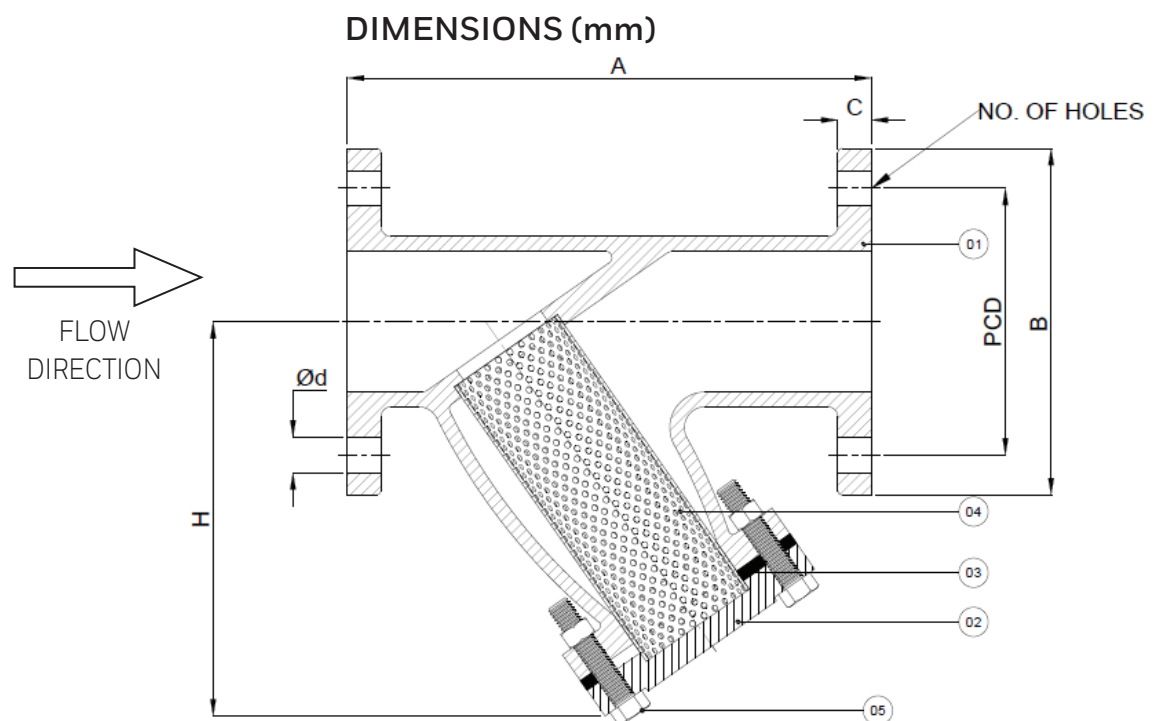

## PART DESCRIPTIONS

PT No.	PART NAME	MATERIAL	SPECIFICATION	Qty
01	Body	Cast Iron	IS 210 Gr. FG 200	1
02	Cover	Cast Iron	IS 210 Gr. FG 200	1
03	Gasket	Rubber	EPDM	1
04	Filter	Screen Stainless Steel	SS304	1
05	Fastners	M.S.	Mild Steel	4
06	Name Plate	Aluminum	Aluminum	1

## OUTSIDE DIMENSION MM (INCH)

DN Size	Face to face (A) $\pm 1.5$	Flange diameter (B) $\pm 2$	Flange thickness (C) $\pm 1.5$	Flange PCD $\pm 1.5$	Height (H) $\pm 3$	No. of Bolts	Bolt Hole Size	Mesh Hole Size $\pm 0.5$	No. of holes per Sq. inch
20 (3/4")	165	105	18	75	142	4	14	$\Phi 1/16"$	67
25 (1")	170	115	18	85	142	4	14	$\Phi 1/16"$	67
32 (1-1/4")	185	140	19	100	145	4	19	$\Phi 1/16"$	67
40 (1-1/2")	205	135	16	110	162	4	19	$\Phi 1/16"$	67
50 (2")	205	154	16	125	175	4	19	$\Phi 1/16"$	67
65 (2-1/2")	220	160	16	145	191	4	19	$\Phi 1/16"$	67
80 (3")	265	186	17	160	225	8	19	$\Phi 1/8"$	27
100 (4")	330	215	20	180	236	8	19	$\Phi 1/8"$	27
125 (5")	418	255	20	210	275	8	19	$\Phi 1/8"$	27
150 (6")	440	285	22	240	325	8	23	$\Phi 1/8"$	27
200 (8")	525	340	23	295	375	12	23	$\Phi 1/8"$	27
250 (10")	725	406	25	355	565	12	28	$\Phi 1/8"$	27
300 (12")	750	480	25	410	670	12	28	$\Phi 1/8"$	27
350 (14")	845	535	30	470	720	16	28	$\Phi 1/8"$	27

### For more information,

[www.honeywellbuildings.in](http://www.honeywellbuildings.in)

Call: 000-8000-502167,

Email: [enquiry.mms@honeywell.com](mailto:enquiry.mms@honeywell.com), [bmsindiatechsupport@honeywell.com](mailto:bmsindiatechsupport@honeywell.com)

### Honeywell HBT India Buildings

Unitech Trade Center, 5th Floor, Sector-43,  
Block C, Sushant Lok Phase - I,  
Gurgaon - 122 002.

**IMPACT**  
by Honeywell