

Axial piston fixed pump AA2FO

RA-A 91401/07.2014
Replaces: 03.08

1/32

Data sheet

Series 6
 Sizes Nominal pressure/Maximum pressure
 10 to 180 5800/6500 psi (400/450 bar)
 250 5100/5800 psi (350/400 bar)
 Open circuits



Contents

Ordering code for standard program	2
Technical data	5
Dimensions sizes 10, 12, 16	12
Dimensions sizes 23, 28, 32	14
Dimensions size 45	16
Dimensions sizes 56, 63	18
Dimensions sizes 80, 90	20
Dimensions sizes 107, 125	22
Dimensions sizes 160, 180	24
Dimensions size 250	26
Installation instructions	28
General instructions	29

Features

- Fixed pump with axial tapered piston rotary group of bent-axis design, for hydrostatic drives in an open circuit
- For use in mobile and stationary applications
- The flow is proportional to the drive speed and displacement
- The drive shaft bearings are designed for the bearing service life requirements usually encountered in these areas
- High power density
- Small dimensions
- High total efficiency
- Economical design
- One-piece tapered piston with piston rings for sealing

Ordering code for standard program

	AA2F		O		/	6			-	V				
01	02	03	04	05		06	07	08		09	10	11	12	13

Hydraulic fluid

01	Mineral oil and HFD. HFD for sizes 250 only in combination with long-life bearing "L" (without code)												
	HFB-, HFC		sizes 10 to 180 (without code)										
	hydraulic fluid		sizes 250 (only in combination with long-life bearing "L")										E-

Axial piston unit

02	Bent axis design, fixed, SAE Version												AA2F
----	--------------------------------------	--	--	--	--	--	--	--	--	--	--	--	-------------

Drive shaft bearing

03											10 to 180	250	
	Standard bearing (without code)										●	●	
	Long-life bearing										-	●	L

Operation mode

04	Pump, open circuit												O
----	--------------------	--	--	--	--	--	--	--	--	--	--	--	----------

Size

05	Geometric displacement, see table of values on page 7									
	size	10	12	16	23	28	32	45	56	
	in ³ /rev.	0.63	0.73	0.98	1.40	1.71	1.95	2.78	3.42	
	size	63	80	90	107	125	160	180	250	
	in ³ /rev.	3.84	4.91	5.49	6.51	7.63	9.79	10.98	15.25	

Series

06													6
----	--	--	--	--	--	--	--	--	--	--	--	--	----------

Index

07											sizes 10 to 180	1
											size 250	0

Direction of rotation

08	Viewed on drive shaft										clockwise	R
											counter-clockwise	L

Seals

09	FKM (fluor-caoutchouc)												V
----	------------------------	--	--	--	--	--	--	--	--	--	--	--	----------

Drive shafts

10			10	12	16	23	28	32	45	56	63	80	90	107	125	160	180	250	
	Splined shaft		●	●	●	●	●	●	●	●	●	-	-	●	●	●	●	●	S
	SAE J744 (ANSI B92.1a)		-	-	-	-	-	-	-	●	●	-	-	-	-	-	-	-	T
			-	-	-	-	-	-	-	-	-	●	●	●	●	-	-	-	U
			-	-	-	-	-	-	-	-	-	●	●	-	-	-	-	-	Q
	Parallel keyed shaft		●	●	●	●	●	-	●	●	●	●	●	●	●	●	●	-	B
DIN 6885		●	●	-	●	●	-	●	●	-	●	-	●	-	●	-	-	P	
SAE parallel keyed shaft		-	-	-	-	-	-	-	-	-	-	-	-	-	-	-	●	K	

Mounting flange

11			10	12	16	23	28	32	45	56	63	80	90	107	125	160	180	250	
	SAE J744		2-hole	●	●	●	-	-	-	-	-	-	-	-	-	-	-	-	C
			4-hole	-	-	-	●	●	●	●	●	-	-	●	●	●	●	●	D
			-	-	-	-	-	-	-	-	-	●	●	-	-	-	-	-	DN

● = Available

- = Not available

Ordering code for standard program

	AA2F		O		/	6			-	V				
01	02	03	04	05		06	07	08		09	10	11	12	13

Port plates for service lines¹⁾

		10, 12, 16	23, 28, 32	45	56, 63	80, 90	107, 125	160, 180	250	
12	SAE flange ports A/B at side and SAE flange port S at rear	-	●	●	●	●	●	●	●	55
	Threaded ports A/B at side and SAE flange port S at rear	●	-	-	-	-	-	-	-	56

Standard / special version

13	Standard version (without code)	
	Standard version with installation variants, e. g. T ports against standard open or closed	-Y
	Special version	-S

● = Available - = Not available

1) Fastening threads or threaded ports are SAE (UN/UNF)

Technical data

Hydraulic fluid

Before starting project planning, please refer to our data sheets RE 90220 (mineral oil), RE 90221 (environmentally acceptable hydraulic fluids), RE 90222 (HFD hydraulic fluids) and RE 90223 (HFA, HFB, HFC hydraulic fluids) for detailed information regarding the choice of hydraulic fluid and application conditions.

The fixed pump AA2FO is not suitable for operation with HFA hydraulic fluid. If HFB, HFC or HFD or environmentally acceptable hydraulic fluids are used, the limitations regarding technical data or other seals must be observed.

Selection diagram

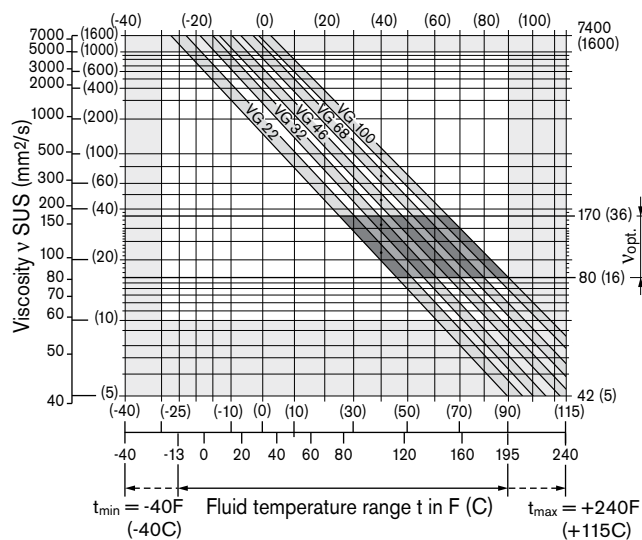

Details regarding the choice of hydraulic fluid

The correct choice of hydraulic fluid requires knowledge of the operating temperature in relation to the ambient temperature: in an open circuit, the reservoir temperature.

The hydraulic fluid should be chosen so that the operating viscosity in the operating temperature range is within the optimum range (v_{opt} see shaded area of the selection diagram). We recommend that the higher viscosity class be selected in each case.

Example: At an ambient temperature of X °F (X °C), an operating temperature of 140 °F (60 °C) is set in the circuit. In the optimum operating viscosity range (v_{opt} , shaded area), this corresponds to the viscosity classes VG 46 or VG 68; to be selected: VG 68.

Note

The case drain temperature, which is affected by pressure and speed, can be higher than the reservoir temperature. At no point of the component may the temperature be higher than 240 °F (115 °C). The temperature difference specified below is to be taken into account when determining the viscosity in the bearing.

If the above conditions cannot be maintained due to extreme operating parameters, we recommend flushing the case at port U (size 250).

Viscosity and temperature of hydraulic fluid

	Viscosity [SUS (mm ² /s)]	Temperature	Comment
Transport and storage at ambient temperature		$T_{min} \geq -58$ °F (-50 °C) $T_{opt} = +41$ °F to +68 °F (+5 °C to +20 °C)	factory preservation: up to 12 months with standard, up to 24 months with long-term
(Cold) start-up ¹⁾	$v_{max} = 7400$ (1600)	$T_{St} \geq -40$ °F (-40 °C)	$t \leq 3$ min, without load ($p \leq 725$ psi (50 bar)), $n \leq 1000$ rpm (for sizes 10 to 180), $n \leq 0.25 \cdot n_{nom}$ (for sizes 250)
Permissible temperature difference		$\Delta T \leq 45$ °F (25 °C)	between axial piston unit and hydraulic fluid
Warm-up phase	$v < 7400$ to 1850 (1600 to 400)	$T = -40$ °F to -13 °F (-40 °C to -25 °C)	at $p \leq 0.7 \cdot p_{nom}$, $n \leq 0.5 \cdot n_{nom}$ and $t \leq 15$ min
Operating phase			
Temperature difference		$\Delta T = \text{approx. } 22$ °F (12 °C)	between hydraulic fluid in the bearing and at port T.
Maximum temperature		+240 °F (115 °C) +217 °F (103 °C)	in the bearing measured at port T
Continuous operation	$v = 1850$ to 47 (400 to 10) $v_{opt} = 170$ to 74 (36 to 16)	$T = -13$ °F to +195 °F (-25 °C to +90 °C)	measured at port T, no restriction within the permissible data
Short-term operation ²⁾	$v_{min} \geq 32$ (7)	$T_{max} = +217$ °F (+103 °C)	measured at port T, $t < 3$ min, $p < 0.3 \cdot p_{nom}$
FKM shaft seal ¹⁾		$T \leq +240$ °F (+115 °C)	see page 5

1) At temperatures below -13 °F (-25 °C), an NBR shaft seal is required (permissible temperature range: -40 °F to +195 °F (-40 °C to +90 °C)).

2) Sizes 250, please contact us.

Technical data

Filtration of the hydraulic fluid

Finer filtration improves the cleanliness level of the hydraulic fluid, which increases the service life of the axial piston unit.

To ensure the functional reliability of the axial piston unit, a gravimetric analysis of the hydraulic fluid is necessary to determine the amount of solid contaminant and to determine the cleanliness level according to ISO 4406. A cleanliness level of at least 20/18/15 is to be maintained.

At very high hydraulic fluid temperatures (+195 °F to +240 °F (90 °C to maximum 115 °C)), a cleanliness level of at least 19/17/14 according to ISO 4406 is necessary.

If the above classes cannot be achieved, please contact us.

Shaft seal

Permissible pressure loading

The service life of the shaft seal is influenced by the speed of the axial piston unit and the case drain pressure (case pressure). The mean differential pressure of 30 psi (2 bar) between the case and the ambient pressure may not be enduringly exceeded at normal operating temperature. For a higher differential pressure at reduced speed, see diagram. Momentary pressure spikes ($t < 0.1$ s) of up to 145 psi (10 bar) are permitted. The service life of the shaft seal decreases with an increase in the frequency of pressure spikes.

The case pressure must be equal to or higher than the ambient pressure.

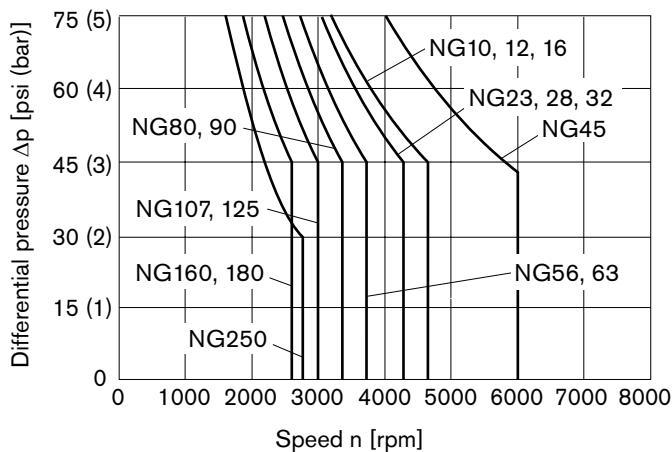

The values are valid for an ambient pressure $p_{abs} = 15$ psi (1 bar).

Temperature range

The FKM shaft seal may be used for case drain temperatures from -13 °F to +240 °F (-25 °C to +115 °C).

Note

For application cases below -13 °F (-25 °C), an NBR shaft seal is required (permissible temperature range: -40 °F to 195 °F (-40 °C to +90 °C). State NBR shaft seal in plain text when ordering.

Please contact us.

Direction of flow

Direction of rotation, viewed on drive shaft

clockwise	counter-clockwise
S to B	S to A

Long-life bearing

Size 250

For long service life and use with HF hydraulic fluids. Identical external dimensions as motor with standard bearings. Subsequent conversion to long-life bearings is possible. Bearing and case flushing via port U is recommended.

Flushing flow (recommended)

Size	250
$q_{v \text{ flush}}$ gpm	2.6
L/min	10

Technical data

Operating pressure range

(operating with mineral oil)

Pressure at service line port A or B

Sizes 10 to 180

Nominal pressure p_{nom} _____ 5800 psi (400 bar) absolute

Maximum pressure p_{max} _____ 6500 psi (450 bar) absolute

Single operating period _____ 10 s

Total operating period _____ 300 h

Sizes 250

Nominal pressure p_{nom} _____ 5100 psi (350 bar) absolute

Maximum pressure p_{max} _____ 5800 psi (400 bar) absolute

Single operating period _____ 10 s

Total operating period _____ 300 h

Minimum pressure (high-pressure side) _____

365 psi (25 bar) absolute

Rate of pressure change $R_{A \max}$

without pressure-relief valve _____ 232000 psi/s (16000 bar/s)

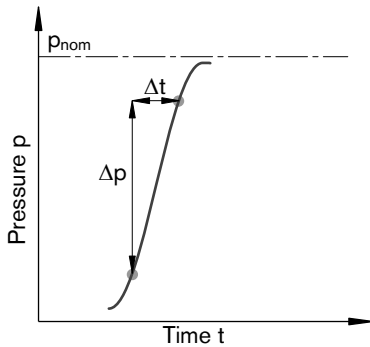

Pressure at suction port S (inlet)

Minimum pressure $p_{S \min}$ _____ 12 psi (0.8 bar) absolute

Maximum pressure $p_{S \max}$ _____ 435 psi (30 bar) absolute

Note

Operation above the maximum values or below the minimum values may result in a loss of function, a reduced service life or in the destruction of the axial piston unit. Other permissible limit values, with respect to speed variation, reduced angular acceleration as a function of the frequency and the permissible start up angular acceleration (lower than the maximum angular acceleration) can be found in data sheet RE 90261.

Definition

Nominal pressure p_{nom}

The nominal pressure corresponds to the maximum design pressure.

Maximum pressure p_{max}

The maximum pressure corresponds to the maximum operating pressure within the single operating period. The sum of the single operating periods must not exceed the total operating period.

Minimum pressure (high-pressure side)

Minimum pressure at the high-pressure side (A or B) which is required in order to prevent damage to the axial piston unit.

Minimum pressure (inlet)

Minimum pressure at suction port S (inlet) which is required in order to prevent damage to the axial piston unit. The minimum pressure is dependent on the speed of the axial piston unit.

Rate of pressure change R_A

Maximum permissible rate of pressure rise and reduction during a pressure change over the entire pressure range.

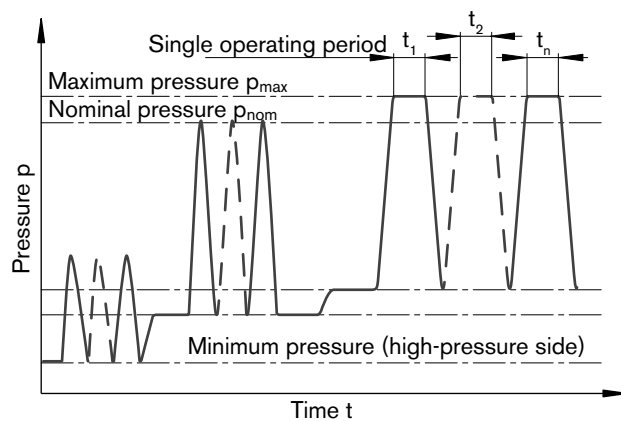

Total operating period = $t_1 + t_2 + \dots + t_n$

Note

Values for other hydraulic fluids, please contact us.

Maximum speed (limiting speed)

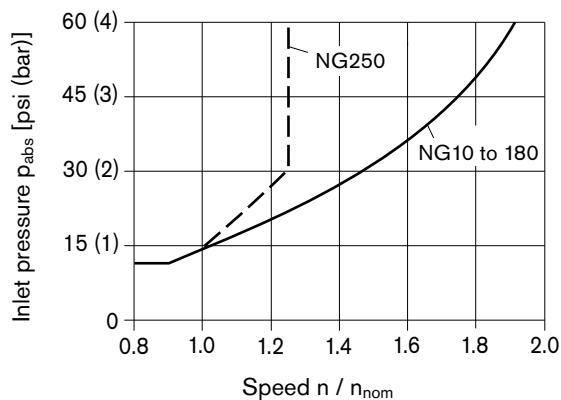

Technical data

Table of values (theoretical values, without efficiency and tolerances; values rounded)

Size	NG		10	12	16	23	28	32	45	56	
Displacement geometric, per revolution	V_g	in^3	0.63	0.73	0.98	1.40	1.71	1.95	2.78	3.42	
		cm^3	10.3	12	16	22.9	28.1	32	45.6	56.1	
Speed maximum ¹⁾	n_{nom}	rpm	3150	3150	3150	2500	2500	2500	2240	2000	
	$n_{\text{max}}^{2)}$	rpm	6000	6000	6000	4750	4750	4750	4250	3750	
Flow at n_{nom}	q_v	gpm	8.6	10.0	13.2	15.1	18.5	21.1	27.0	29.6	
		L/min	32	38	50	57	70	80	102	112	
Power at	$\Delta p = 5100 \text{ psi}$	P	HP	25	30	39	44	55	63	80	88
			kW	19	22	29	33	41	47	60	65
			HP	30	34	45	51	63	71	91	100
			kW	22	25	34	38	47	53	68	75
Torque ³⁾ at V_g and	$\Delta p = 5100 \text{ psi}$	T	lb-ft	42	50	65	94	116	132	189	232
			Nm	57	67	89	128	157	178	254	313
			lb-ft	48	56	75	107	131	150	214	263
			Nm	66	76	102	146	179	204	290	357
Rotary stiffness	c	kNm/rad	0.92	1.25	1.59	2.56	2.93	3.12	4.18	5.94	
Moment of inertia for rotary group	J_{GR}	lbs-ft ²	0.0095	0.0095	0.0095	0.0285	0.0285	0.0285	0.0569	0.0997	
		kgm ²	0.0004	0.0004	0.0004	0.0012	0.0012	0.0012	0.0024	0.0042	
Maximum angular acceleration	α	rad/s ²	5000	5000	5000	6500	6500	6500	14600	7500	
Case volume	V	gal	0.045	0.045	0.045	0.053	0.053	0.053	0.087	0.119	
		L	0.17	0.17	0.17	0.20	0.20	0.20	0.33	0.45	
Mass (approx.)	m	lbs	12	12	12	21	21	21	30	40	
		kg	6	6	6	9.5	9.5	9.5	13.5	18	

Size	NG		63	80	90	107	125	160	180	250	
Displacement geometric, per revolution	V_g	in^3	3.84	4.91	5.49	6.51	7.63	9.79	10.98	15.25	
		cm^3	63	80.4	90	106.7	125	160.4	180	250	
Speed maximum ¹⁾	n_{nom}	rpm	2000	1800	1800	1600	1600	1450	1450	1500	
	$n_{\text{max}}^{2)}$	rpm	3750	3350	3350	3000	3000	2650	2650	1800	
Flow at n_{nom}	q_v	gpm	33.3	38.0	42.8	44.9	52.8	61.2	69.0	99.1	
		L/min	126	145	162	171	200	233	261	375	
Power at	$\Delta p = 5100 \text{ psi}$	P	HP	99	113	127	134	157	183	205	295
			kW	74	84	95	100	117	136	152	219
			HP	113	129	145	153	179	208	233	–
			kW	84	96	108	114	133	155	174	–
Torque ³⁾ at V_g and	$\Delta p = 5100 \text{ psi}$	T	lb-ft	260	331	372	442	517	664	746	1036
			Nm	351	448	501	594	696	893	1003	1393
			lb-ft	295	377	422	500	586	752	845	–
			Nm	401	512	573	679	796	1021	1146	–
Rotary stiffness	c	kNm/rad	6.25	8.73	9.14	11.2	11.9	17.4	18.2	73.1	
Moment of inertia for rotary group	J_{GR}	lbs-ft ²	0.0997	0.1708	0.1708	0.2753	0.2753	0.5221	0.5221	1.4475	
		kgm ²	0.0042	0.0072	0.0072	0.0116	0.0116	0.0220	0.0220	0.061	
Maximum angular acceleration	α	rad/s ²	7500	6000	6000	4500	4500	3500	3500	10000	
Case volume	V	gal	0.119	0.145	0.145	0.211	0.211	0.291	0.291	0.660	
		L	0.45	0.55	0.55	0.8	0.8	1.1	1.1	2.5	
Mass (approx.)	m	lbs	40	51	51	71	71	99	99	161	
		kg	18	23	23	32	32	45	45	73	

1) The values are valid:

- at an absolute pressure $p_{\text{abs}} = 1 \text{ bar}$ at suction port S
- for the optimum viscosity range from $v_{\text{opt}} = 170 \text{ to } 74 \text{ SUS}$ (16 to 36 mm²/s)
- with hydraulic fluid based on mineral oils

2) Maximum speed (limiting speed) with increased inlet pressure p_{abs} at suction port S, see maximum speed on page 6.

3) Torque without radial force, with radial force see page 8.

Technical data

Determining the operating characteristics

Flow $q_v = \frac{V_g \cdot n \cdot \eta_v}{231}$ gpm $\left(q_v = \frac{V_g \cdot n \cdot \eta_v}{1000} \right)$ L/min

Torque $T = \frac{V_g \cdot \Delta p}{24 \cdot \pi \cdot \eta_{mh}}$ lb-ft $\left(T = \frac{V_g \cdot \Delta p}{20 \cdot \pi \cdot \eta_{mh}} \right)$ Nm

Power $P = \frac{2 \pi \cdot T \cdot n}{33\,000} = \frac{q_v \cdot \Delta p}{1714 \cdot \eta_t}$ HP $\left(P = \frac{2 \pi \cdot T \cdot n}{60\,000} = \frac{q_v \cdot \Delta p}{600 \cdot \eta_t} \right)$ kW

V_g = Displacement per revolution in in³ (cm³)

Δp = Differential pressure in psi (bar)

n = Speed in rpm

η_v = Volumetric efficiency

η_{mh} = Mechanical-hydraulic efficiency

η_t = Total efficiency ($\eta_t = \eta_v \cdot \eta_{mh}$)

Effect of radial force F_q on the service life of bearings

By selecting a suitable direction of radial force F_q , the load on the bearings, caused by the internal rotary group forces can be reduced, thus optimizing the service life of the bearings. Recommended position of mating gear is dependent on direction of rotation. Examples:

	Toothed gear drive	V-belt output
NG	φ_{opt}	φ_{opt}
10 to 180	$\pm 70^\circ$	$\pm 45^\circ$
250	$\pm 45^\circ$	$\pm 70^\circ$

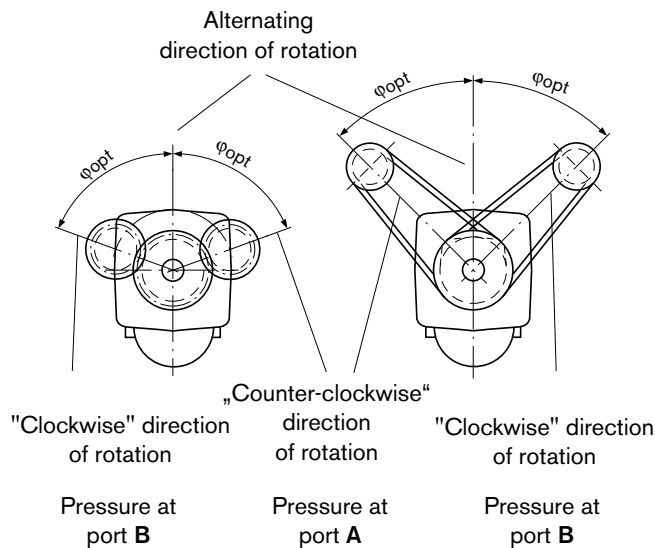

Technical data

Permissible radial and axial forces of the drive shafts

(splined shaft and parallel keyed shaft)

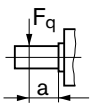
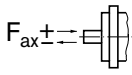
Size	NG		10	10	10	12	12	12	16 ³⁾	16	
Drive shaft	\emptyset	in	7/8	0.79	0.98	7/8	0.79	0.98	7/8	0.98	
		mm	–	20	25	–	20	25	–	25	
Maximum radial force ¹⁾ at distance a (from shaft collar)		$F_{q \max}$	lbf	629.5	674.4	719.4	741.9	674.4	719.4	966.7	719.4
			kN	2.8	3.0	3.2	3.3	3.0	3.2	4.3	3.2
	a	in	0.63	0.63	0.63	0.63	0.63	0.63	0.63	0.63	0.63
		mm	16.8	16	16	16.8	16	16	16.8	16	
with permissible torque	T_{\max}	lb-ft	49	49	49	56.1	56.1	56.9	74.8	74.8	
		Nm	66	66	66	76	76	76	102	102	
\triangleq permissible pressure Δp	Δp_{perm}	psi	5800	5800	5800	5800	5800	5800	5550	5800	
		bar	400	400	400	400	400	400	385	400	
Maximum axial force ²⁾		$+F_{\text{ax max}}$	N	0	0	0	0	0	0	0	
			lbf	71.9	71.9	71.9	71.9	71.9	71.9	71.9	71.9
		$-F_{\text{ax max}}$	N	320	320	320	320	320	320	320	320
			lbf/psi	0.05	0.05	0.05	0.05	0.05	0.05	0.05	0.05
Permissible axial force per psi (bar) operating pressure	$\pm F_{\text{ax perm}} / p$	N/bar	3.0	3.0	3.0	3.0	3.0	3.0	3.0	3.0	

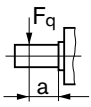
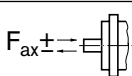
Size	NG		23	23	23	28	28	28	32	32	
Drive shaft	\emptyset	in	1 1/4	0.98	1.18	1 1/4	0.98	1.18	1 1/4	1.18	
		mm	–	25	30	–	25	30	–	30	
Maximum radial force ¹⁾ at distance a (from shaft collar)		$F_{q \max}$	lbf	809.3	1281.4	1213.9	989.1	1281.4	1213.9	1146.5	1213.9
			kN	3.6	5.7	5.4	4.4	5.7	5.4	5.1	5.4
	a	in	0.94	0.63	0.63	0.94	0.63	0.63	0.94	0.63	
		mm	24	16	16	24	16	16	24	16	
with permissible torque	T_{\max}	lb-ft	108	108	108	132	132	132	150.5	150.5	
		Nm	146	146	146	179	179	179	204	204	
\triangleq permissible pressure Δp	Δp_{perm}	psi	5800	5800	5800	5800	5800	5800	5800	5800	
		bar	400	400	400	400	400	400	400	400	
Maximum axial force ²⁾		$+F_{\text{ax max}}$	N	0	0	0	0	0	0	0	
			lbf	112.2	112.2	112.2	112.2	112.2	112.2	112.2	112.2
		$-F_{\text{ax max}}$	N	500	500	500	500	500	500	500	500
			lbf/psi	0.08	0.08	0.08	0.08	0.08	0.08	0.08	0.08
Permissible axial force per psi (bar) operating pressure	$\pm F_{\text{ax perm}} / p$	N/bar	5.2	5.2	5.2	5.2	5.2	5.2	5.2	5.2	

1) With intermittent operation

2) Maximum permissible axial force during standstill or when the axial piston unit is operating in non-pressurized condition.

3) Restricted technical data



Note



Influence of the direction of the permissible axial force:

$+F_{\text{ax max}}$ = Increase in service life of bearings

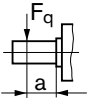
$-F_{\text{ax max}}$ = Reduction in service life of bearings (avoid)

Technical data

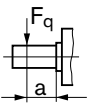
Size	NG		45	45	56 ³⁾	56	56	56	63 ³⁾	63	63	
Drive shaft	ø	in	1 1/4	1.18	1 1/4	1 3/8	1.18	1.37	1 1/4	1 3/8	1.38	
		mm	–	30	–	–	30	35	–	–	35	
Maximum radial force ¹⁾ at distance a (from shaft collar)		$F_{q \max}$	lbf	1641	1709	1709	2068	2136	2045	1708	2315	2046
			kN	7.3	7.6	7.6	9.2	9.5	9.1	7.6	10.3	9.1
	a	in	0.94	0.71	0.94	0.94	0.71	0.71	0.94	0.94	0.71	
		mm	24	18	24	24	18	18	24	24	18	
with permissible torque	T_{\max}	lb-ft	214	214	223	263	263	263	223	295	295	
		Nm	290	290	302	357	357	357	302	401	401	
Δ permissible pressure Δp	Δp _{perm}	psi	5800	5800	4950	5800	5800	5800	4350	5800	5800	
		bar	400	400	339	400	400	400	301	400	400	
Maximum axial force ²⁾		$+F_{ax \max}$	N	0	0	0	0	0	0	0	0	
			lbf	142	142	180	180	180	180	180	180	180
		$-F_{ax \max}$	N	630	630	800	800	800	800	800	800	800
			lbf	142	142	180	180	180	180	180	180	180
Permissible axial force per psi (bar) operating pressure	$\pm F_{ax \text{ perm}} / p$	lbf/psi	0.11	0.11	0.13	0.13	0.13	0.13	0.13	0.13	0.13	
		N/bar	7.0	7.0	8.7	8.7	8.7	8.7	8.7	8.7	8.7	

Size	NG		80 ³⁾	80 ³⁾	80	80	90 ³⁾	90 ³⁾	90	107 ³⁾	107	
Drive shaft	ø	in	1 1/4	1 3/8	1.37	1.57	1 1/4	1 3/8	1.57	1 1/2	1 3/4	
		mm	–	–	35	40	–	–	40	–	–	
Maximum radial force ¹⁾ at distance a (from shaft collar)		$F_{q \max}$	lbf	1709	2608	2608	2563	1709	2608	2563	2788	2743
			kN	7.6	11.6	11.6	11.4	7.6	11.6	11.4	12.4	12.2
	a	in	0.94	0.94	0.79	0.79	0.94	0.94	0.79	1.06	1.32	
		mm	24	24	20	20	24	24	20	27	33.5	
with permissible torque	T_{\max}	lb-ft	223	332	378	378	223	332	423	438	501	
		Nm	302	450	512	512	302	450	573	594	679	
Δ permissible pressure Δp	Δp _{perm}	psi	3450	5100	5800	5800	3050	4550	5800	5100	5800	
		bar	237	352	400	400	211	314	400	349	400	
Maximum axial force ²⁾		$+F_{ax \max}$	N	0	0	0	0	0	0	0	0	
			lbf	225	225	225	225	225	225	225	281	281
		$-F_{ax \max}$	N	1000	1000	1000	1000	1000	1000	1000	1250	1250
			lbf	225	225	225	225	225	225	225	281	281
Permissible axial force per psi (bar) operating pressure	$\pm F_{ax \text{ perm}} / p$	lbf/psi	0.16	0.16	0.16	0.16	0.16	0.16	0.16	0.20	0.20	
		N/bar	10.6	10.6	10.6	10.6	10.6	10.6	10.6	12.9	12.9	

1) With intermittent operation

2) Maximum permissible axial force during standstill or when the axial piston unit is operating in non-pressurized condition.

3) Restricted technical data

Note

Influence of the direction of the permissible axial force:

$+F_{ax \max}$ = Increase in service life of bearings

$-F_{ax \max}$ = Reduction in service life of bearings (avoid)

Technical data

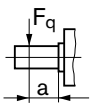
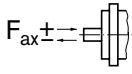
Size	NG		107	107	125 ³⁾	125	125	160 ³⁾	160	160	180 ³⁾	180	250	
Drive shaft	ø	in	1.57	1.77	1 1/2	1 3/4	1.77	1 3/4	1.77	1.97	1 3/4	1.97	1.97	
		mm	40	45	-	-	45	-	45	50	-	50	50	
Maximum radial force ¹⁾ at distance a (from shaft collar)		$F_{q \max}$	lbf	3057	3169	2788	3215	3170	3350	4069	4114	3350	4114	270 ⁵⁾
			kN	13.6	14.1	12.4	14.3	14.1	14.9	18.1	18.3	14.9	18.3	1.2 ⁵⁾
	a	in	0.79	0.79	1.06	1.32	0.79	1.32	0.98	0.98	1.32	0.98	1.61	
		mm	20	20	27	33.5	20	33.5	25	25	33.5	25	41	
with permissible torque	T_{\max}	lb-ft	501	501	438	587	587	611	753	753	611	844	4)	
		Nm	679	679	594	796	796	828	1021	1021	828	1146		
△ permissible pressure Δp	Δp_{perm}	psi	5800	5800	4350	5800	5800	4700	5800	5800	4200	5800	4)	
		bar	400	400	298	400	400	325	400	400	289	400		
Maximum axial force ²⁾		$+F_{ax \max}$	N	0	0	0	0	0	0	0	0	0	0	
		$-F_{ax \max}$	lbf	281	281	281	281	281	360	360	360	360	360	450
			N	1250	1250	1250	1250	1250	1600	1600	1600	1600	1600	2000
Permissible axial force per psi (bar) operating pressure	$\pm F_{ax \text{ perm}} / p$	lbf/psi	0.20	0.20	0.20	0.20	0.20	0.26	0.26	0.26	0.26	0.26	4)	
		N/bar	12.9	12.9	12.9	12.9	12.9	16.7	16.7	16.7	16.7	16.7		

- 1) With intermittent operation
- 2) Maximum permissible axial force during standstill or when the axial piston unit is operating in non-pressurized condition.
- 3) Restricted technical data
- 4) Please contact us.
- 5) When at a standstill or when axial piston unit operating in non-pressurized conditions. Higher forces are permissible when under pressure, please contact us.

Note

Influence of the direction of the permissible axial force:

$+F_{ax \max}$ = Increase in service life of bearings

$-F_{ax \max}$ = Reduction in service life of bearings (avoid)

Dimensions sizes 10, 12, 16 – SAE design

Before finalizing your design, request a binding installation drawing. Dimensions in inch and (millimeters).

Clockwise rotation Counter-clockwise rotation: port plate is rotated through 180°

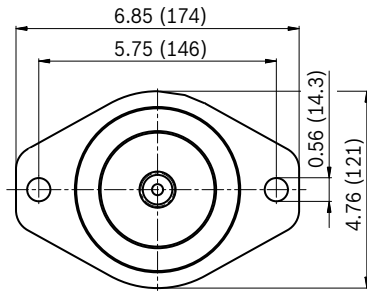
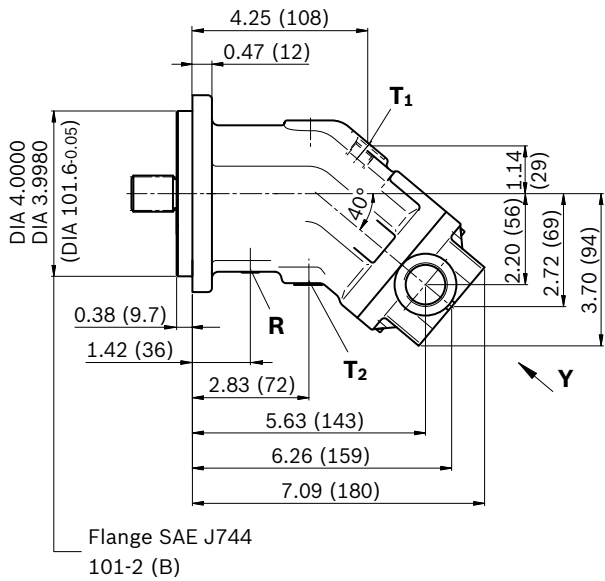

Detail Y

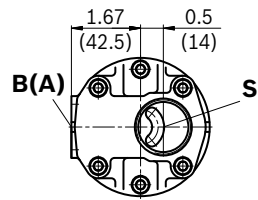

Before finalizing your design, request a binding installation drawing. Dimensions in inch and (millimeters).

Shaft ends

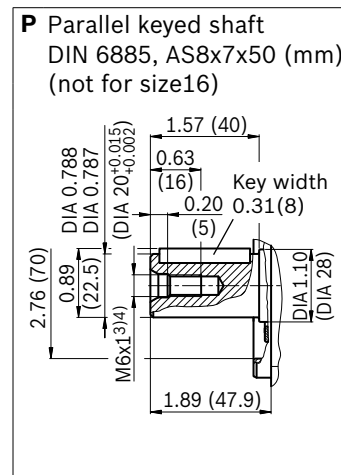
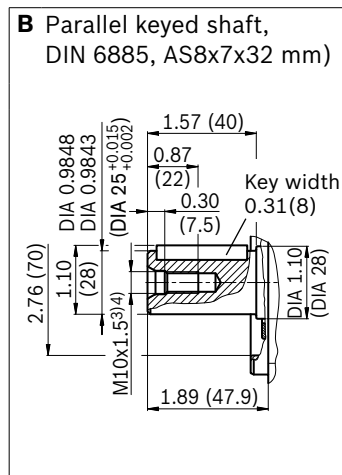
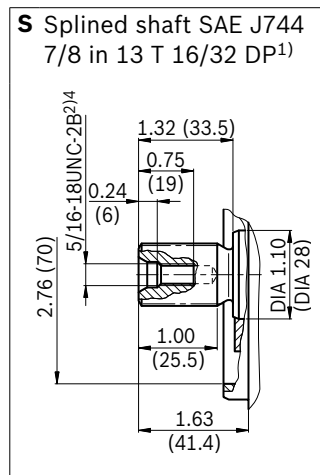

Ports

Designation	Port for	Standard ⁶⁾	Size ⁴⁾	p _{max} [psi (bar)] ⁵⁾	State ⁸⁾
B (A)	Service line	ISO 11926	1 1/16 in -12UN-2B; 0.79 (20) deep	265 lb-ft (360 Nm) ⁴⁾	O
S	Suction	ISO 11926	1 5/16 in -12UN-2B; 0.79 (20) deep	400 lb-ft (540 Nm) ⁴⁾	O
T ₁	Drain line	ISO 11926	9/16 in -18UNF-2B; 0.51 (13) deep	60 lb-ft (80 Nm) ⁴⁾	O ⁷⁾
T ₂	Drain line	ISO 11926	9/16 in -18UNF-2B; 0.51 (13) deep	60 lb-ft (80 Nm) ⁴⁾	X ⁷⁾
R	Air bleed	ISO 11926	5/16 in -24UNF-2B; 0.39 (10) deep	7 lb-ft (10 Nm) ⁴⁾	X ⁷⁾

- 1) ANSI B92.1a, 30° pressure angle, flat root, side fit, tolerance class 5
- 2) Thread according to ASME B1.1
- 3) Center bore according to DIN 332 (thread according to DIN 13)
- 4) Observe the general instructions on page 30 for the maximum tightening torques.
- 5) Momentary pressure spikes may occur depending on the application. Keep this in mind when selecting measuring devices and fittings.
- 6) The spot face can be deeper than specified in the appropriate standard.
- 7) Depending on installation position, T₁ or T₂ must be connected (see also installation instructions on page 28)
- 8) O = Must be connected (plugged on delivery)
X = Plugged (in normal operation)

Dimensions sizes 23, 28, 32 – SAE design

Before finalizing your design, request a binding installation drawing. Dimensions in inch and (millimeters).

Clockwise rotation Counter-clockwise rotation: port plate is rotated through 180°

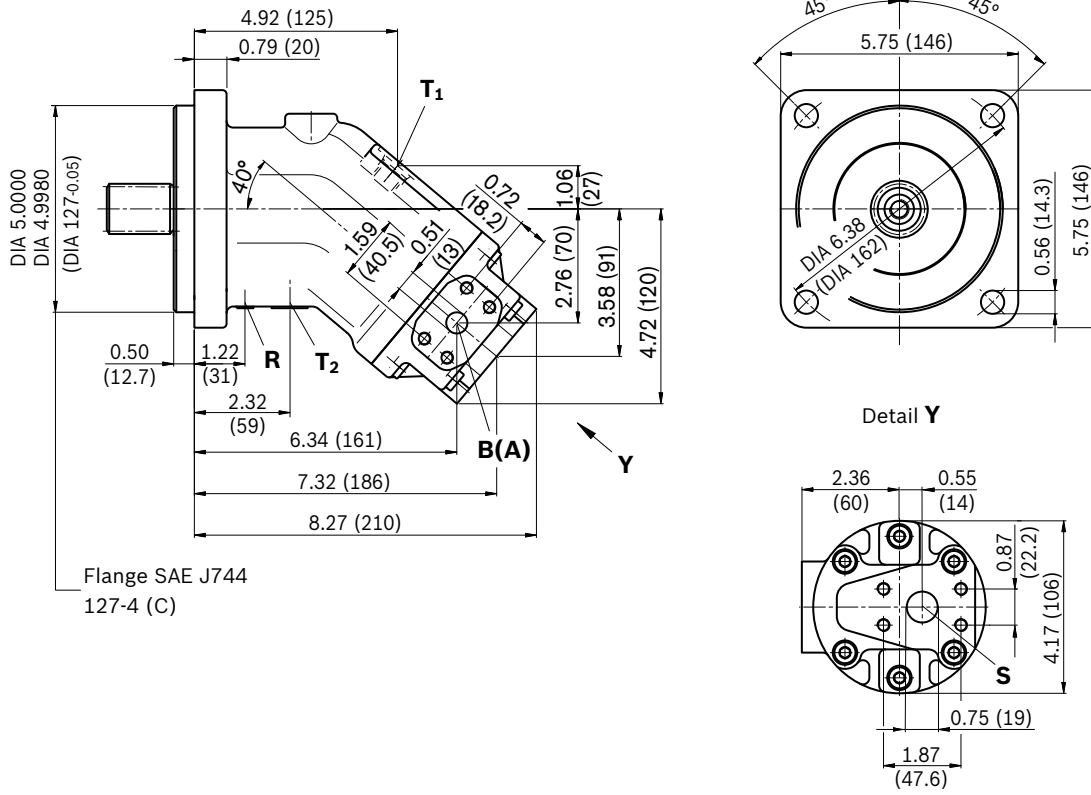

Before finalizing your design, request a binding installation drawing. Dimensions in inch and (millimeters).

Shaft ends

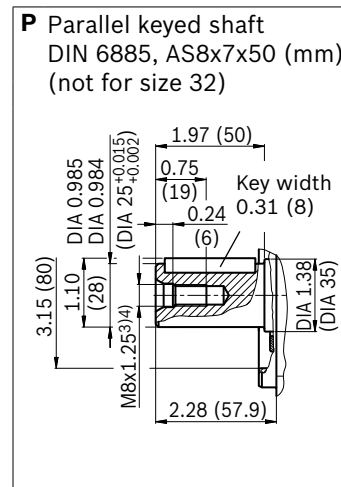
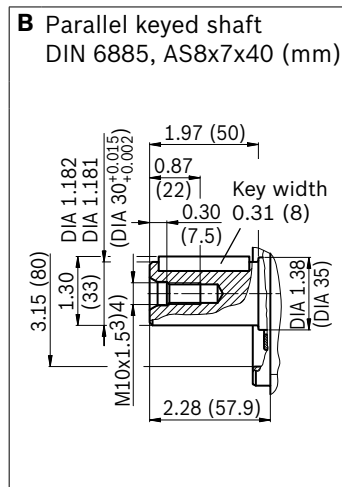
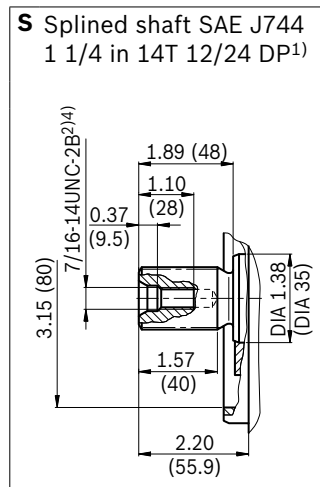

Ports

Designation	Port for	Standard ⁶⁾	Size ⁴⁾	p _{max} [psi (bar)] ⁵⁾	State ⁸⁾
B (A)	Service line	SAE J518	1/2 in		O
	Fastening threads B/A	ASME 31.1	5/16 in -18UNC-2B; 0.71 (18) deep		
S	Suction	SAE J518	3/4 in		O
	Fastening threads	ASME 31.1	3/8 in -16UNC-2B; 0.79 (20) deep		
T ₁	Drain line	ISO 11926	3/4 in -16UNF-2B; 0.59 (15) deep	120 lb-ft (160 Nm) ⁴⁾	O ⁷⁾
T ₂	Drain line	ISO 11926	3/4 in -16UNF-2B; 0.59 (15) deep	120 lb-ft (160 Nm) ⁴⁾	X ⁷⁾
R	Air bleed	ISO 11926	5/16 in -24UNF-2B; 0.39 (10) deep	7 lb-ft (10 Nm) ⁴⁾	X ⁷⁾

- 1) ANSI B92.1a, 30° pressure angle, flat root, side fit, tolerance class 5
- 2) Thread according to ASME B1.1
- 3) Center bore according to DIN 332 (thread according to DIN 13)
- 4) Observe the general instructions on page 30 for the maximum tightening torques.
- 5) Momentary pressure spikes may occur depending on the application. Keep this in mind when selecting measuring devices and fittings.
- 6) The spot face can be deeper than specified in the appropriate standard.
- 7) Depending on installation position, T₁ or T₂ must be connected (see also installation instructions on page 28)
- 8) O = Must be connected (plugged on delivery)
X = Plugged (in normal operation)

Dimensions size 45 – SAE design

Before finalizing your design, request a binding installation drawing. Dimensions in inch and (millimeters).

Clockwise rotation Counter-clockwise rotation: port plate is rotated through 180°

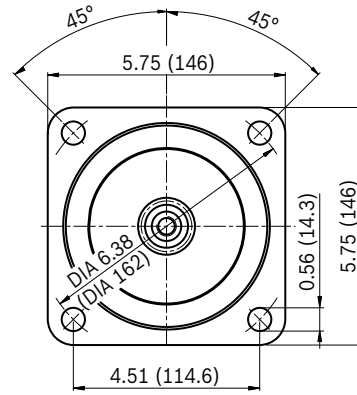
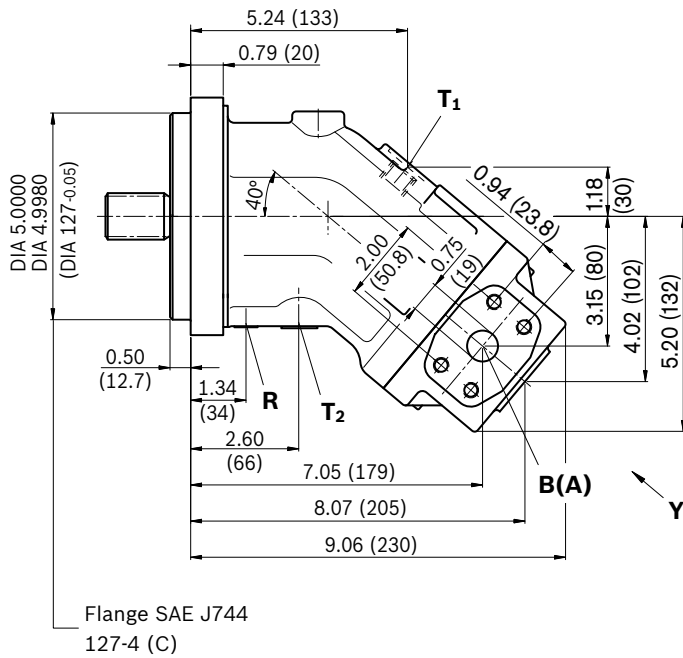

Detail Y

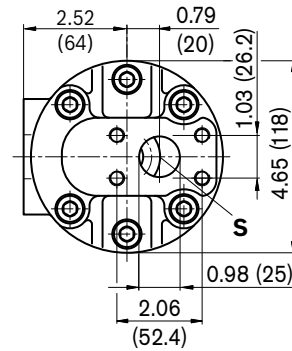

Before finalizing your design, request a binding installation drawing. Dimensions in inch and (millimeters).

Shaft ends

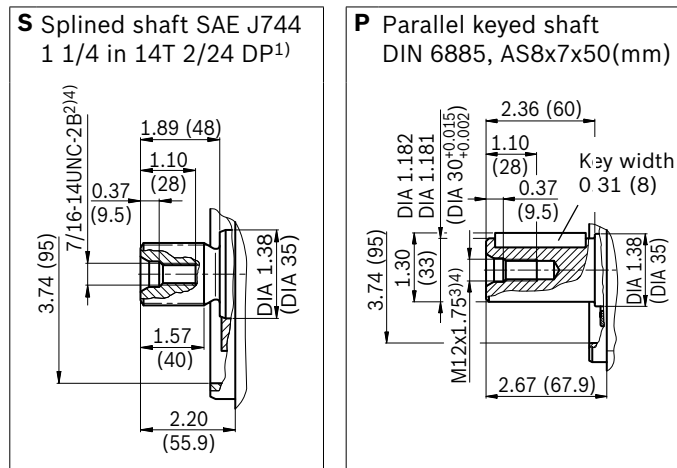

Ports

Designation	Port for	Standard ⁶⁾	Size ⁴⁾	p_{max} [psi (bar)] ⁵⁾	State ⁸⁾
B (A)	Service line	SAE J518	3/4 in		O
	Fastening threads B/A	ASME 31.1	3/8 in -16UNC-2B; 0.82 (21) deep		
S	Suction	SAE J518	1 in		O
	Fastening threads	ASME 31.1	3/8 in -16UNC-2B; 0.79 (20) deep		
T ₁	Drain line	ISO 11926	3/4 in -16UNF-2B; 0.59 (15) deep	120 lb-ft (160 Nm) ⁴⁾	O ⁷⁾
T ₂	Drain line	ISO 11926	3/4 in -16UNF-2B; 0.59 (15) deep	120 lb-ft (160 Nm) ⁴⁾	X ⁷⁾
R	Air bleed	ISO 11926	7/16 in -24UNF-2B; 0.47 (12) deep	30 lb-ft (40 Nm) ⁴⁾	X ⁷⁾

- 1) ANSI B92.1a, 30° pressure angle, flat root, side fit, tolerance class 5
- 2) Thread according to ASME B1.1
- 3) Center bore according to DIN 332 (thread according to DIN 13)
- 4) Observe the general instructions on page 30 for the maximum tightening torques.
- 5) Momentary pressure spikes may occur depending on the application. Keep this in mind when selecting measuring devices and fittings.
- 6) The spot face can be deeper than specified in the appropriate standard.
- 7) Depending on installation position, T₁ or T₂ must be connected (see also installation instructions on page 28)
- 8) O = Must be connected (plugged on delivery)
X = Plugged (in normal operation)

Dimensions sizes 56, 63 – SAE design

Before finalizing your design, request a binding installation drawing. Dimensions in inch and (millimeters).

Clockwise rotation Counter-clockwise rotation: port plate is rotated through 180°

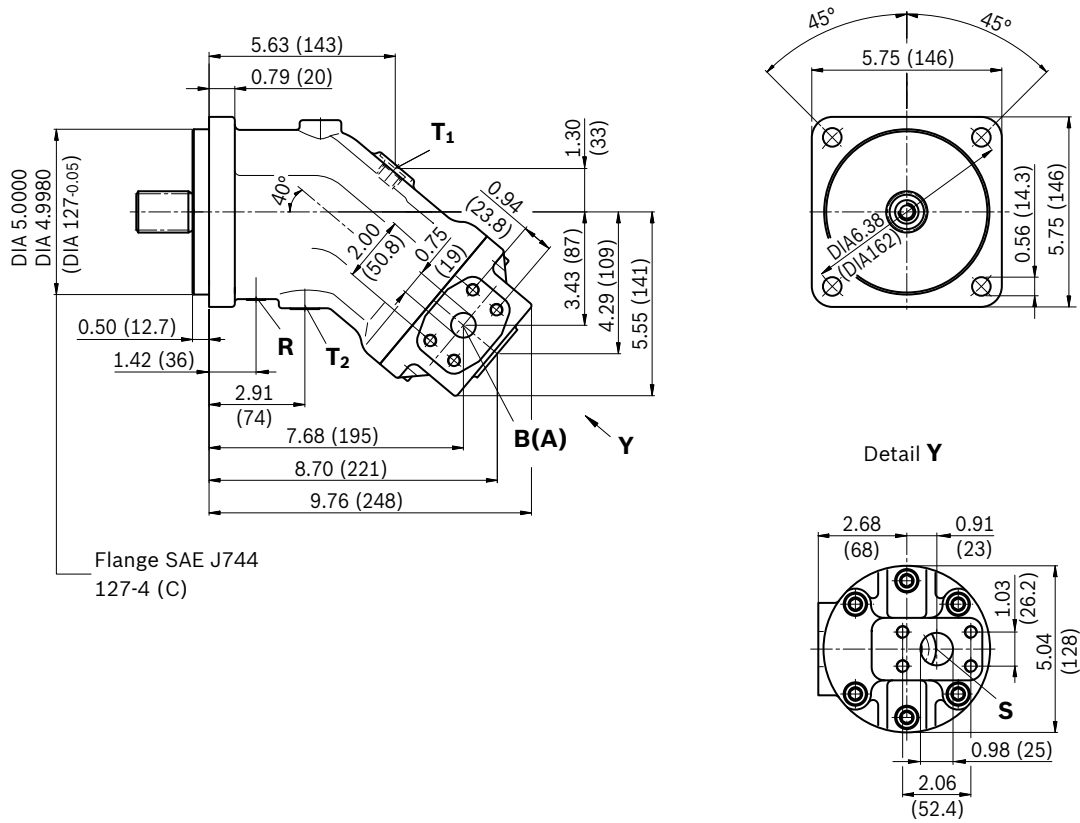

Before finalizing your design, request a binding installation drawing. Dimensions in inch and (millimeters).

Shaft ends

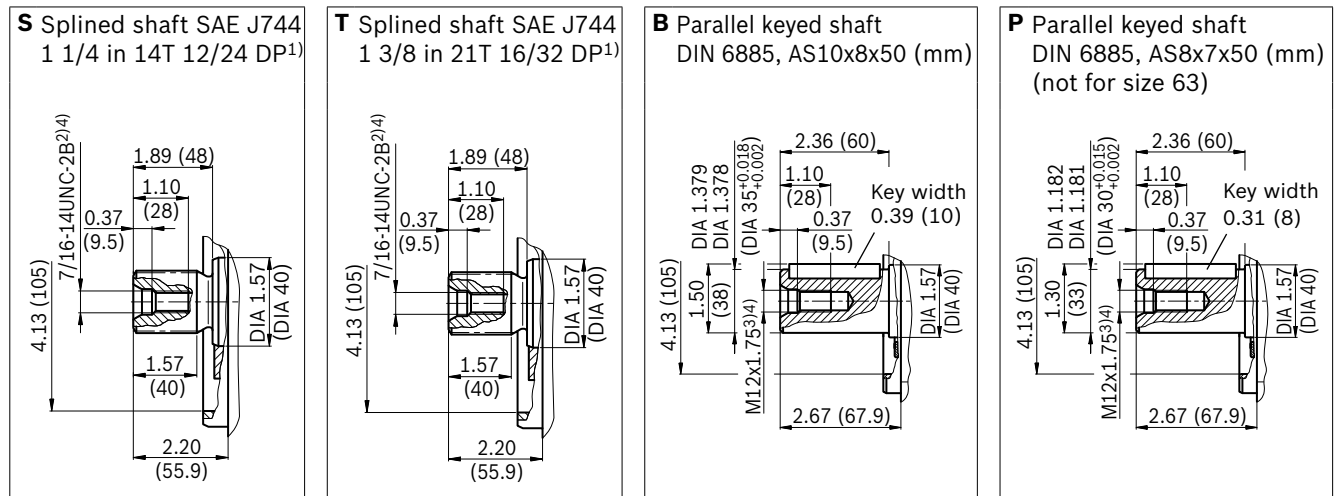

Ports

Designation	Port for	Standard ⁶⁾	Size ⁴⁾	p_{max} [psi (bar)] ⁵⁾	State ⁸⁾
B (A)	Service line	SAE J518	3/4 in		O
	Fastening threads B/A	ASME 31.1	3/8 in -16UNC-2B; 0.82 (21) deep		
S	Suction	SAE J518	1 in		O
	Fastening threads	ASME 31.1	3/8 in -16UNC-2B; 0.79 (20) deep		
T ₁	Drain line	ISO 11926	3/4 in -16UNF-2B; 0.59 (15) deep	120 lb-ft (160 Nm) ⁴⁾	O ⁷⁾
T ₂	Drain line	ISO 11926	3/4 in -16UNF-2B; 0.59 (15) deep	120 lb-ft (160 Nm) ⁴⁾	X ⁷⁾
R	Air bleed	ISO 11926	7/16 in -24UNF-2B; 0.47 (12) deep	30 lb-ft (40 Nm) ⁴⁾	X ⁷⁾

- 1) ANSI B92.1a, 30° pressure angle, flat root, side fit, tolerance class 5
- 2) Thread according to ASME B1.1
- 3) Center bore according to DIN 332 (thread according to DIN 13)
- 4) Observe the general instructions on page 30 for the maximum tightening torques.
- 5) Momentary pressure spikes may occur depending on the application. Keep this in mind when selecting measuring devices and fittings.
- 6) The spot face can be deeper than specified in the appropriate standard.
- 7) Depending on installation position, T₁ or T₂ must be connected (see also installation instructions on page 28)
- 8) O = Must be connected (plugged on delivery)
X = Plugged (in normal operation)

Dimensions sizes 80, 90 – SAE design

Before finalizing your design, request a binding installation drawing. Dimensions in inch and (millimeters).

Clockwise rotation Counter-clockwise rotation: port plate is rotated through 180°

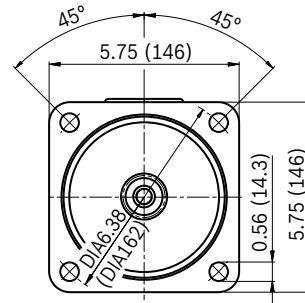
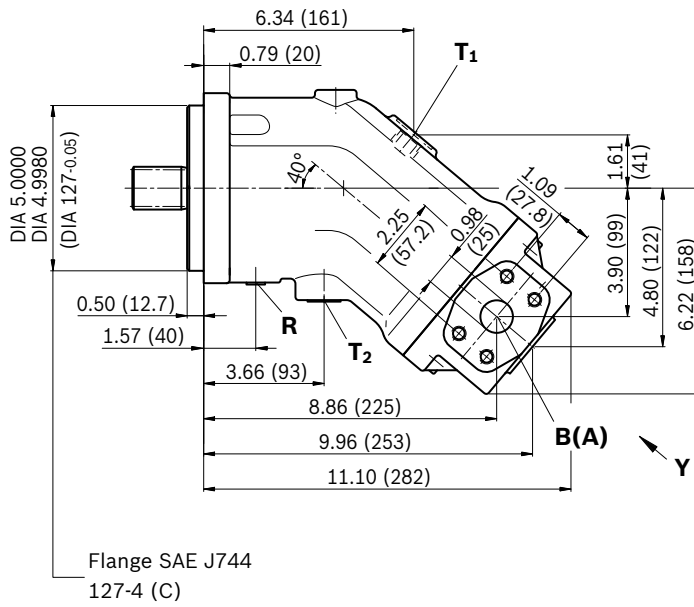

Detail Y

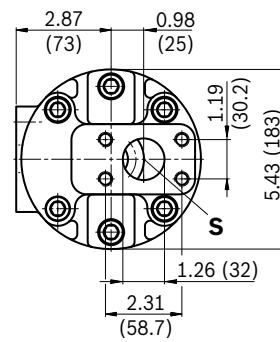

Before finalizing your design, request a binding installation drawing. Dimensions in inch and (millimeters).

Shaft ends

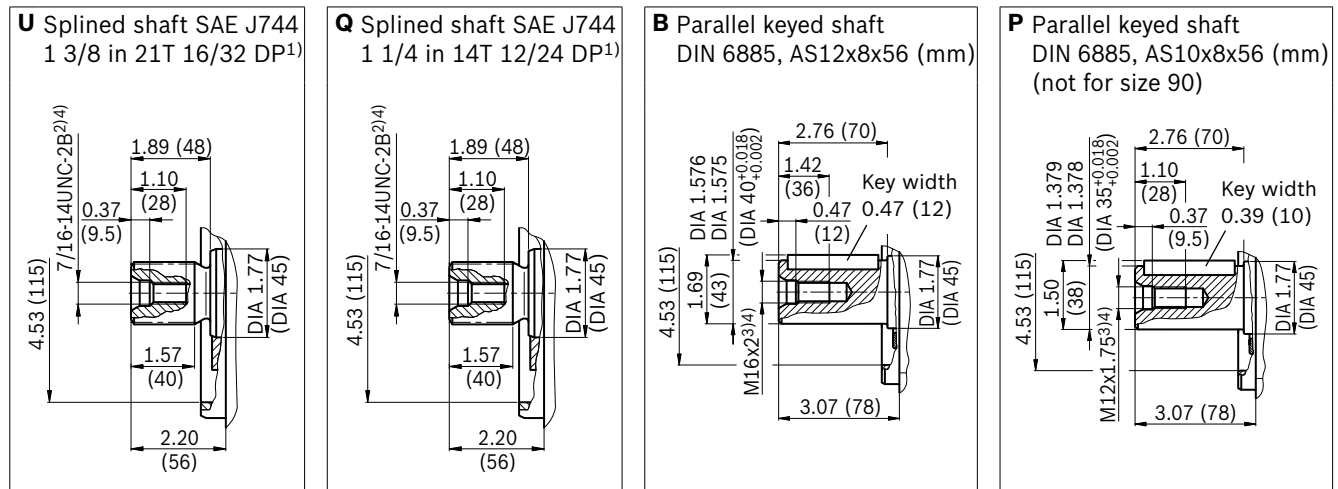

Ports

Designation	Port for	Standard ⁶⁾	Size ⁴⁾	p_{max} [psi (bar)] ⁵⁾	State ⁸⁾
B (A)	Service line	SAE J518	1 in		O
	Fastening threads B/A	ASME 31.1	7/16 in -14UNC-2B; 0.87 (22) deep		
S	Suction	SAE J518	1 1/4 in		O
	Fastening threads	ASME 31.1	7/16 in -14UNC-2B; 1.02 (26) deep		
T ₁	Drain line	ISO 11926	7/8 in -14UNF-2B; 0.67 (17) deep	180 lb-ft (240 Nm) ⁴⁾	O ⁷⁾
T ₂	Drain line	ISO 11926	7/8 in -14UNF-2B; 0.67 (17) deep	180 lb-ft (240 Nm) ⁴⁾	X ⁷⁾
R	Air bleed	ISO 11926	7/16 in -20UNF-2B; 0.47 (12) deep	30 lb-ft (40 Nm) ⁴⁾	X ⁷⁾

- 1) ANSI B92.1a, 30° pressure angle, flat root, side fit, tolerance class 5
- 2) Thread according to ASME B1.1
- 3) Center bore according to DIN 332 (thread according to DIN 13)
- 4) Observe the general instructions on page 30 for the maximum tightening torques.
- 5) Momentary pressure spikes may occur depending on the application. Keep this in mind when selecting measuring devices and fittings.
- 6) The spot face can be deeper than specified in the appropriate standard.
- 7) Depending on installation position, T₁ or T₂ must be connected (see also installation instructions on page 28)
- 8) O = Must be connected (plugged on delivery)
X = Plugged (in normal operation)

Dimensions sizes 107, 125 – SAE design

Before finalizing your design, request a binding installation drawing. Dimensions in inch and (millimeters).

Clockwise rotation Counter-clockwise rotation: port plate is rotated through 180°

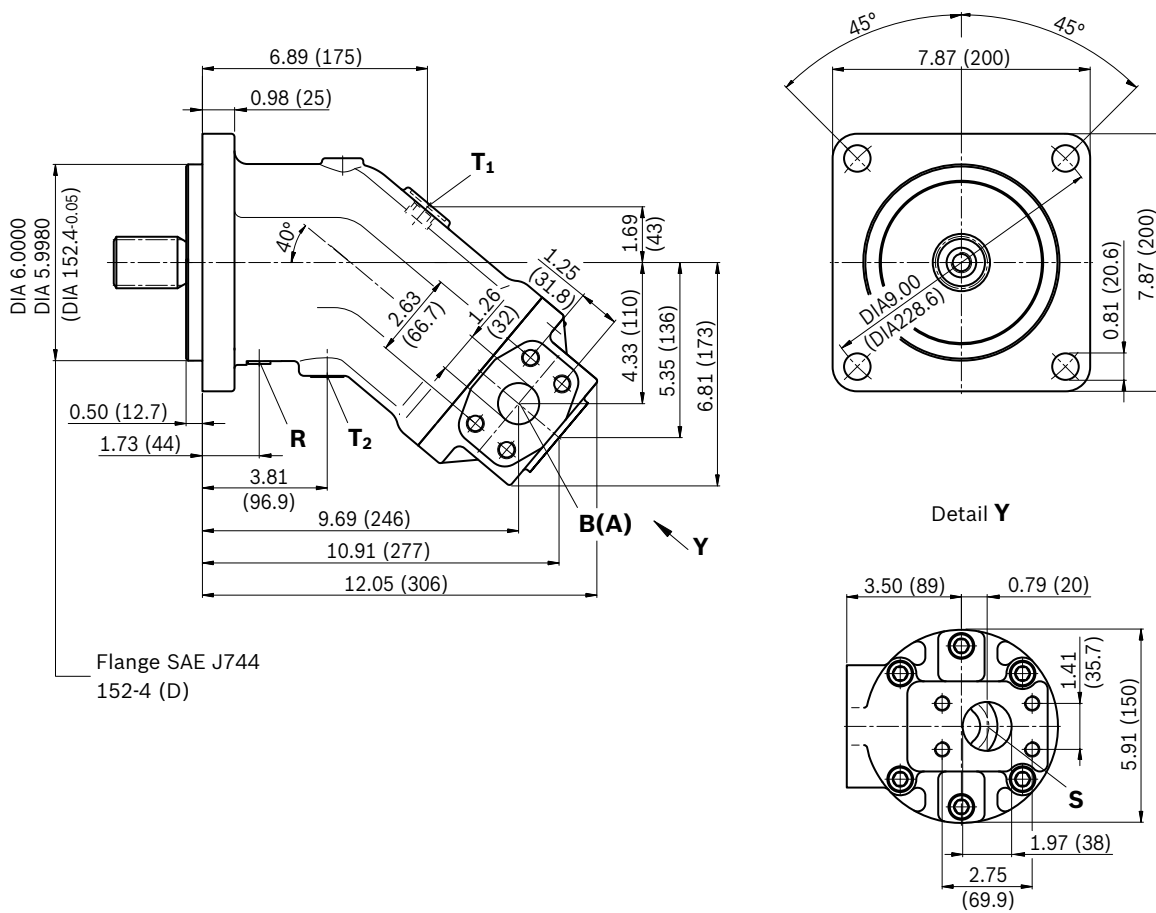

Before finalizing your design, request a binding installation drawing. Dimensions in inch and (millimeters).

Shaft ends

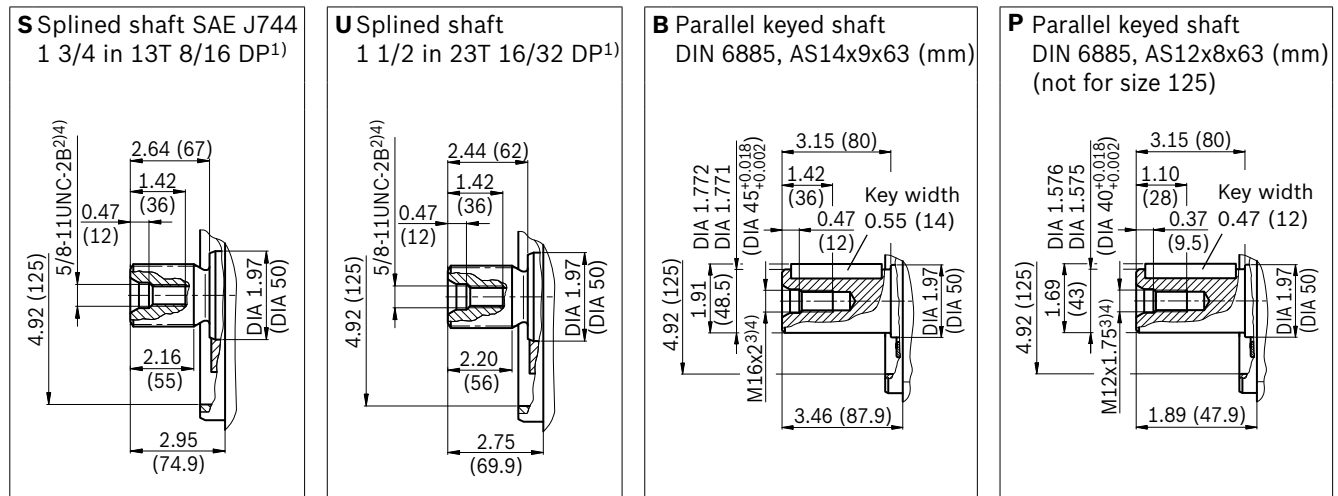

Ports

Designation	Port for	Standard ⁶⁾	Size ⁴⁾	p _{max} [psi (bar)] ⁵⁾	State ⁸⁾
B (A)	Service line	SAE J518	1 1/4 in		O
	Fastening threads B/A	ASME 31.1	1/2 in -13UNC-2B; 0.75 (19) deep		
S	Suction	SAE J518	1 1/4 in		O
	Fastening threads	ASME 31.1	7/16 in -14UNC-2B; 0.95 (24) deep		
T ₁	Drain line	ISO 11926	7/8 in -14UNF-2B; 0.67 (17) deep	180 lb-ft (240 Nm) ⁴⁾	O ⁷⁾
T ₂	Drain line	ISO 11926	7/8 in -14UNF-2B; 0.67 (17) deep	180 lb-ft (240 Nm) ⁴⁾	X ⁷⁾
R	Air bleed	ISO 11926	7/16 in -20UNF-2B; 0.47 (12) deep	30 lb-ft (40 Nm) ⁴⁾	X ⁷⁾

- 1) ANSI B92.1a, 30° pressure angle, flat root, side fit, tolerance class 5
- 2) Thread according to ASME B1.1
- 3) Center bore according to DIN 332 (thread according to DIN 13)
- 4) Observe the general instructions on page 30 for the maximum tightening torques.
- 5) Momentary pressure spikes may occur depending on the application. Keep this in mind when selecting measuring devices and fittings.
- 6) The spot face can be deeper than specified in the appropriate standard.
- 7) Depending on installation position, T₁ or T₂ must be connected (see also installation instructions on page 28)
- 8) O = Must be connected (plugged on delivery)
X = Plugged (in normal operation)

Dimensions sizes 160, 180 – SAE design

Before finalizing your design, request a binding installation drawing. Dimensions in inch and (millimeters).

Clockwise rotation Counter-clockwise rotation: port plate is rotated through 180°

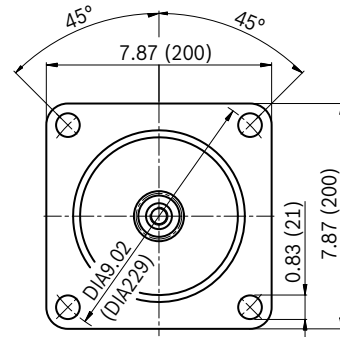
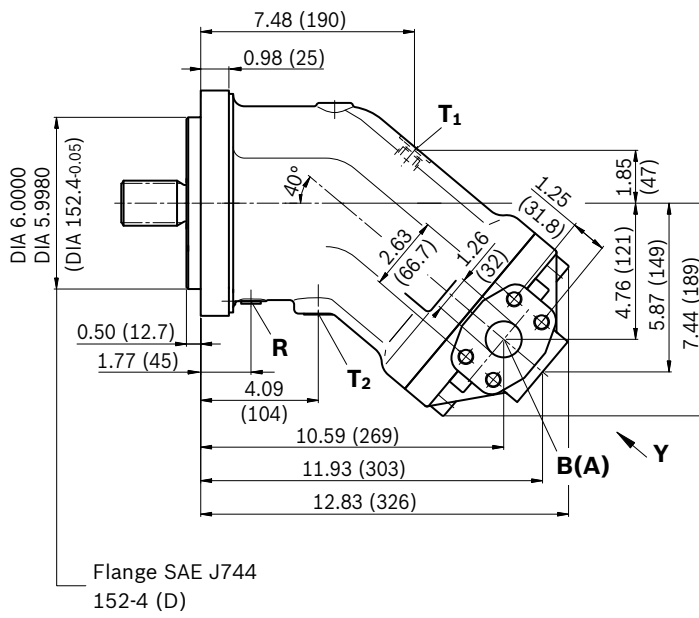

Detail Y

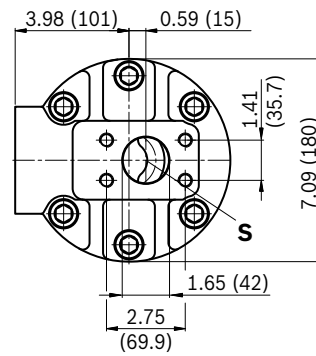

Before finalizing your design, request a binding installation drawing. Dimensions in inch and (millimeters).

Shaft ends

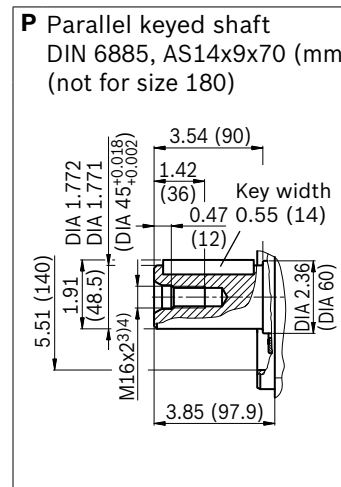
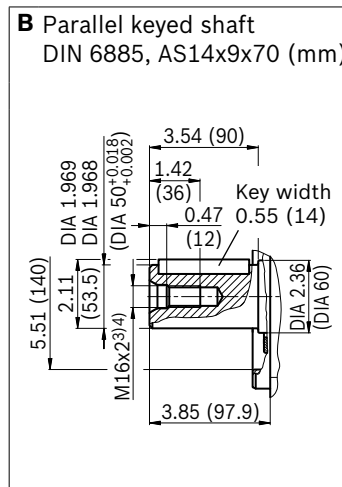
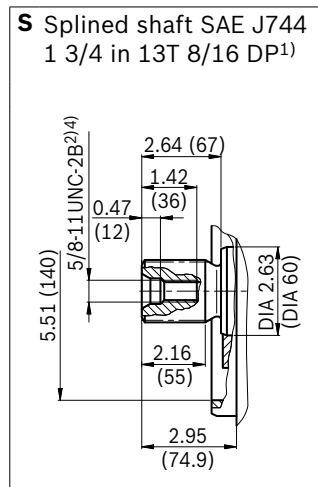

Ports

Designation	Port for	Standard ⁶⁾	Size ⁴⁾	p _{max} [psi (bar)] ⁵⁾	State ⁸⁾
B (A)	Service line	SAE J518	1 1/4 in		O
	Fastening threads B/A	ASME 31.1	1/2 in -13UNC-2B; 0.75 (19) deep		
S	Suction	SAE J518	1 1/2 in		O
	Fastening threads	ASME 31.1	1/2 in -13UNC-2B; 0.95 (24) deep		
T ₁	Drain line	ISO 11926	7/8 in -14UNF-2B; 0.67 (17) deep	180 lb-ft (240 Nm) ⁴⁾	O ⁷⁾
T ₂	Drain line	ISO 11926	7/8 in -14UNF-2B; 0.67 (17) deep	180 lb-ft (240 Nm) ⁴⁾	X ⁷⁾
R	Air bleed	ISO 11926	9/16 in -20UNF-2B; 0.51 (13) deep	60 lb-ft (80 Nm) ⁴⁾	X ⁷⁾

- 1) ANSI B92.1a, 30° pressure angle, flat root, side fit, tolerance class 5
- 2) Thread according to ASME B1.1
- 3) Center bore according to DIN 332 (thread according to DIN 13)
- 4) Observe the general instructions on page 30 for the maximum tightening torques.
- 5) Momentary pressure spikes may occur depending on the application. Keep this in mind when selecting measuring devices and fittings.
- 6) The spot face can be deeper than specified in the appropriate standard.
- 7) Depending on installation position, T₁ or T₂ must be connected (see also installation instructions on page 28)
- 8) O = Must be connected (plugged on delivery)
X = Plugged (in normal operation)

Dimensions size 250 – SAE design

Before finalizing your design, request a binding installation drawing. Dimensions in inch and (millimeters).

Clockwise rotation Counter-clockwise rotation: port plate is rotated through 180°

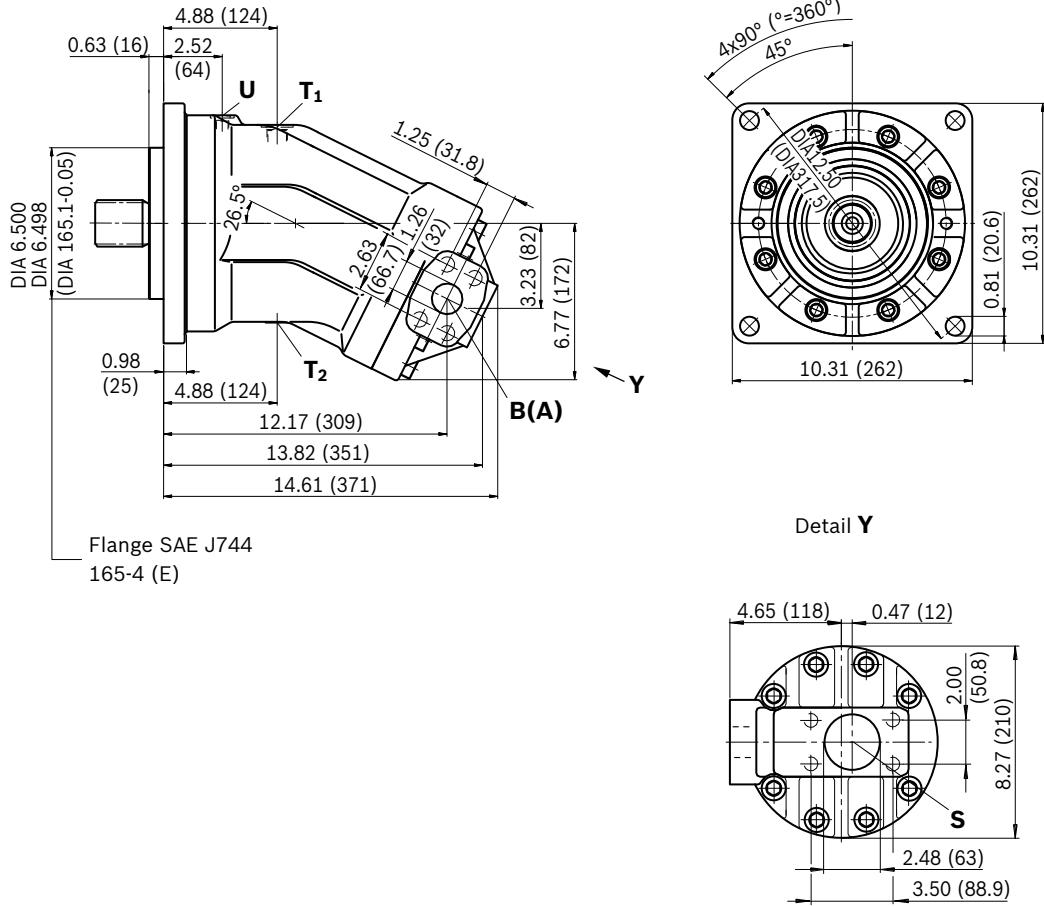

Before finalizing your design, request a binding installation drawing. Dimensions in inch and (millimeters).

Shaft ends

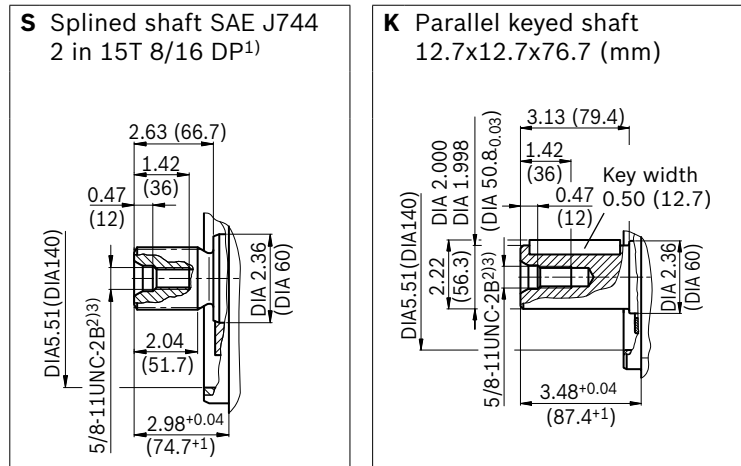

Ports

Designation	Port for	Standard ⁶⁾	Size ⁴⁾	p _{max} [psi (bar)] ⁵⁾	State ⁸⁾
B (A)	Service line	SAE J518	1 1/4 in		O
	Fastening threads B/A	ASME 31.1	1/2 in -13UNC-2B; 0.79 (20) deep		
S	Suction	SAE J518	2 1/2 in		O
	Fastening threads	ASME 31.1	1/2 in -13UNC-2B; 0.79 (20) deep		
T ₁	Drain line	ISO 11926	7/8 in -14UNF-2B; 0.67 (17) deep	180 lb-ft (240 Nm) ⁴⁾	O ⁷⁾
T ₂	Drain line	ISO 11926	7/8 in -14UNF-2B; 0.67 (17) deep	180 lb-ft (240 Nm) ⁴⁾	X ⁷⁾
U	Bearing flushing (plugged)	ISO 11926	9/16 in -20UNF-2B; 0.51 (13) deep	60 lb-ft (80 Nm) ⁴⁾	X ⁷⁾

- 1) ANSI B92.1a, 30° pressure angle, flat root, side fit, tolerance class 5
- 2) Thread according to ASME B1.1
- 3) Center bore according to DIN 332 (thread according to DIN 13)
- 4) Observe the general instructions on page 30 for the maximum tightening torques.
- 5) Momentary pressure spikes may occur depending on the application. Keep this in mind when selecting measuring devices and fittings.
- 6) The spot face can be deeper than specified in the appropriate standard.
- 7) Depending on installation position, T₁ or T₂ must be connected (see also installation instructions on page 28)
- 8) O = Must be connected (plugged on delivery)
X = Plugged (in normal operation)

Installation instructions

Before finalizing your design, request a binding installation drawing. Dimensions in inch and (millimeters).

General

During commissioning and operation, the axial piston unit must be filled with hydraulic fluid and air bled. This must also be observed following a relatively long standstill as the axial piston unit may drain back to the reservoir via the hydraulic lines.

Particularly in the installation position "drive shaft upwards" filling and air bleeding must be carried out completely as there is, for example, a danger of dry running.

The case drain fluid in the pump housing must be directed to the reservoir via the highest available drain port (T_1, T_2).

For combinations of multiple units, make sure that the respective case pressure in each unit is not exceeded. In the event of pressure differences at the drain ports of the units, the shared drain line must be changed so that the minimum permissible case pressure of all connected units is not exceeded in any situation. If this is not possible, separate drain lines must be laid if necessary.

To achieve favorable noise values, decouple all connecting lines using elastic elements and avoid above-reservoir installation.

In all operating conditions, the suction and drain lines must flow into the reservoir below the minimum fluid level. The permissible suction height h_s results from the overall loss of pressure; it must not, however, be higher than $h_{S\ max} = 800\ mm$. The minimum suction pressure at port S must also not fall below 0.8 bar absolute during operation and during cold start.

Installation position

See the following examples 1 to 8.
Further installation positions are possible upon request.
Recommended installation positions: 1 and 2.

Note

With sizes 10 to 180 with installation position "shaft upward", an air-bleed port R is required (state in plain text when ordering - special version). With size 250, port U is provided as standard in the area near the bearings for air bleeding.

Installation position	Air bleed	Filling
1	–	T_1
2	–	T_2
3	–	T_1
4	R (U)	T_2
5	L_1	$T_1 (L_1)$
6	L_1	$T_2 (L_1)$
7	L_1	$T_1 (L_1)$
8	R (U)	$T_2 (L_1)$

Below-reservoir installation (standard)

Below-reservoir installation means that the axial piston unit is installed outside of the reservoir below the minimum fluid level.

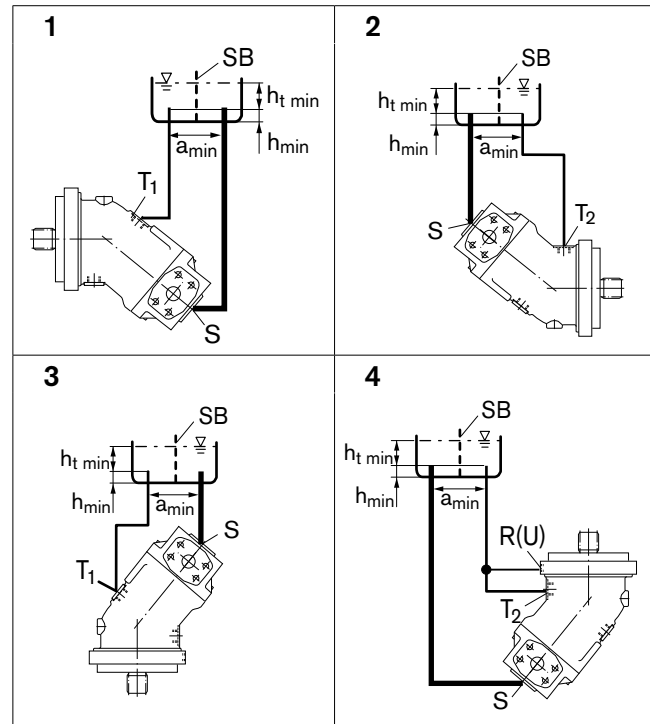

- L₁** Filling / air bleed
- R** Air bleed port
- U** Bearing flushing / air bleed port
- S** Suction port
- T₁, T₂** Drain port
- h_{t min}** Minimum required immersion depth (200 mm)
- h_{min}** Minimum required spacing to reservoir bottom (100 mm)
- SB** Baffle (baffle plate)
- h_{S max}** Maximum permissible suction height (800 mm)
- a_{min}** When designing the reservoir, ensure adequate space between the suction line and the drain line. This prevents the heated, return flow from being drawn directly back into the suction line.

Before finalizing your design, request a binding installation drawing. Dimensions in inch and (millimeters).

Above-reservoir installation

Above-reservoir installation means that the axial piston unit is installed above the minimum fluid level of the reservoir.

Recommendation for installation position 8 (drive shaft upward): A check valve in the drain line (cracking pressure 7.5 psi (0.5 bar)) can prevent draining of the pump housing.

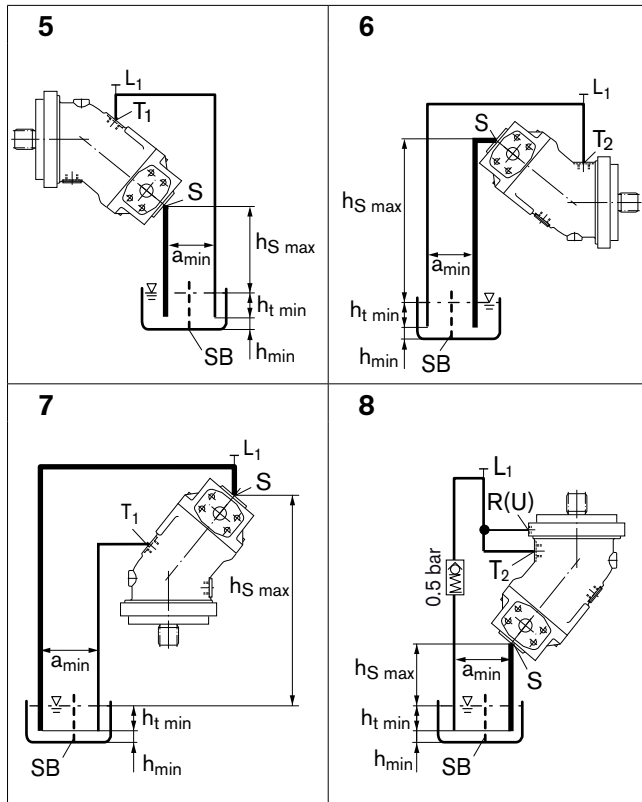

General instructions

- The pump AA2FO is designed to be used in open and closed circuits.
- The project planning, installation and commissioning of the axial piston unit requires the involvement of qualified personnel.
- Before using the axial piston unit, please read the corresponding instruction manual completely and thoroughly. If necessary, these can be requested from Bosch Rexroth.
- During and shortly after operation, there is a risk of burns on the axial piston unit. Take appropriate safety measures (e. g. by wearing protective clothing).
- Depending on the operating conditions of the axial piston unit (operating pressure, fluid temperature), the characteristic may shift.
- Service line ports:
 - The ports and fastening threads are designed for the specified maximum pressure. The machine or system manufacturer must ensure that the connecting elements and lines correspond to the specified application conditions (pressure, flow, hydraulic fluid, temperature) with the necessary safety factors.
 - The service line ports and function ports can only be used to accommodate hydraulic lines.
- The data and notes contained herein must be adhered to.
- Not all versions of the product are approved for use in a safety function pursuant to ISO 13849. If you require characteristic values relating to reliability (e. g. $MTTF_d$) for functional safety, please consult the responsible contact person at Bosch Rexroth.
- The following tightening torques apply:
 - Fittings:
 - Observe the manufacturer's instructions regarding tightening torques of the fittings used.
 - Mounting bolts:
 - For mounting bolts with metric ISO thread according to DIN 13 or with thread according to ASME B1.1, we recommend checking the tightening torque in individual cases in accordance with VDI 2230.
 - Female threads in the axial piston unit:
 - The maximum permissible tightening torques $M_{G \max}$ are maximum values for the female threads and must not be exceeded.
 - Threaded plugs:
 - For the metallic threaded plugs supplied with the axial piston unit, the required tightening torques of threaded plugs M_V apply.

Ports		Maximum permissible tightening torque of the female threads $M_{G \max}$	Required tightening torque of the threaded plugs M_V	WAF hexagon socket of the threaded plugs
Standard	Size of thread			
ISO 11926	5/16-24 UNF-2B	7 lb-ft	5 lb-ft	1/8 in
		10 Nm	7 Nm	
	7/16-20 UNF-2B	29 lb-ft	13 lb-ft	3/16 in
		40 Nm	18 Nm	
	9/16-18 UNF-2B	59 lb-ft	26 lb-ft	1/4 in
		80 Nm	35 Nm	
	3/4-16 UNF-2B	118 lb-ft	52 lb-ft	5/16 in
		160 Nm	70 Nm	
	7/8-14 UNF-2B	177 lb-ft	81 lb-ft	3/8 in
		240 Nm	110 Nm	
	1 1/16-12 UN-2B	266 lb-ft	125 lb-ft	9/16 in
		360 Nm	170 Nm	
	1 5/16-12 UN-2B	398 lb-ft	199 lb-ft	5/8 in
		540 Nm	270 Nm	

Bosch Rexroth Corporation
 Mobile Applications
 8 Southchase Court
 Fountain Inn, SC 29644-9018, USA
 Telephone (864) 967-2777
 Facsimile (864) 967-8900
 www.boschrexroth-us.com

© Bosch Rexroth Corporation

All rights reserved. Neither this document, nor any part of it, may be reproduced, duplicated, circulated or disseminated, whether by copy, electronic format or any other means, without the prior consent and authorization of Bosch Rexroth Corp.

The data and illustrations in this brochure/data sheet are intended only to describe or depict the products. No representation or warranty, either express or implied, relating to merchantability or fitness for intended use, is given or intended by virtue of the information contained in this brochure/data sheet. The information contained in this brochure/data sheet in no way relieves the user of its obligation to insure the proper use of the products for a specific use or application. All products contained in this brochure/data sheet are subject to normal wear and tear from usage.

Subject to change.